

Distributed by
Raymarine

Any reference to Raytheon or RTN in this manual should be interpreted as Raymarine. The names Raytheon and RTN are owned by the Raytheon Company.

ST6000 Plus Autopilot Control Unit

Owner's Handbook

Document number: 81133_3
Date: 1st April 1999

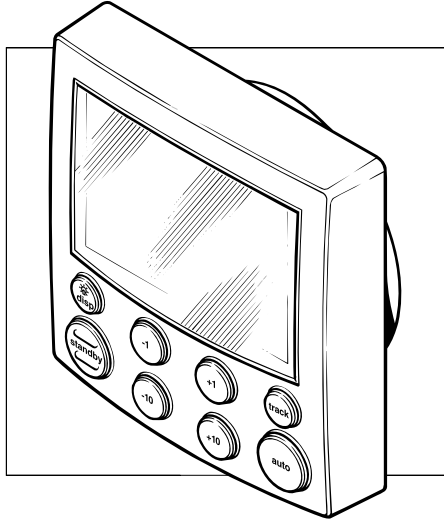

Raytheon Electronics, as part of its commitment to continuous improvement and updating, reserve the right to make changes, without prior notice, to the equipment, equipment specifications, and the instructions contained within this handbook.

To the best of our knowledge, the information contained within this handbook was correct as it went to press.

A great deal of care has been taken to ensure that this handbook is as accurate as possible. However, liability cannot be accepted for inaccuracies or omissions.

Autohelm and SeaTalk are registered trademarks of Raytheon Electronics

WindTrim, AutoTack, AutoTrim, AutoSeastate, AutoAdapt, AutoRelease and CodeLock are trademarks of Raytheon Electronics

Copyright © Raytheon Electronics 1996

Preface

This handbook contains information on the operation and installation of your new equipment. In order to obtain the best performance from your autopilot, please read this handbook thoroughly.

How this handbook is organised

This handbook is divided into the following chapters:

Chapter 1: Introduces the autopilot, its features and its use.

Chapter 2: Covers basic autopilot operation.

Chapter 3: Explains how to use Track and Vane (WindTrim) modes and adjust autopilot performance, and summarises the ST6000 Plus alarms.

Chapter 4: Explains how to use the CodeLock security feature.

Chapter 5: Provides details on how to make adjustments to customise the autopilot to your particular vessel.

Chapter 6: Explains how to install the ST6000 Plus.

Chapter 7: Covers functional testing and initial calibration procedures after installation, and initial sea trials.

Chapter 8: Provides general maintenance procedures.

Chapter 9: Provides information to help you resolve any problems you may encounter with your autopilot.

An index is included at the end of this handbook, followed by a template for the installation of the control unit.

Safety information

Passage making under autopilot control is an enjoyable experience that can, if you are not careful, lead to the relaxation of the permanent watch. A permanent watch **MUST** be maintained no matter how clear the sea may appear to be.

WARNING:

Remember, a large ship can travel two miles in five minutes – just the time it takes to make a cup of coffee.

The following rules should always be observed:

- Maintain a permanent watch and regularly check all around for other vessels and obstacles to navigation – no matter how clear the sea may appear a dangerous situation can develop rapidly.
- Maintain an accurate record of the vessel’s position either by use of a radio navigation receiver or visual bearings.
- Maintain a continuous plot of position on a current chart. Ensure the locked autopilot heading steers you clear of all obstacles. Make proper allowance for Tidal Set – the autopilot cannot!
- Even when your autopilot is locked onto the desired Track using a radio navigation receiver, always maintain a log and make regular positional plots. Radio navigation signals can produce significant errors under some circumstances and the autopilot cannot detect this situation.
- Make sure that all members of crew are familiar with the procedures to disengage the autopilot.

Your Raytheon autopilot will add a new dimension to your boating enjoyment. However, it is the responsibility of the skipper to ensure the safety of the vessel at all times by careful observance of these basic rules.

EMC conformance

All Raytheon equipment and accessories are designed to the best industry standards for use in the leisure marine environment.

Their design and manufacture conforms to the appropriate Electromagnetic Compatibility (EMC) standards, but correct installation is required to ensure that performance is not compromised.

Warranty

To verify the ownership of your new autopilot, please take a few minutes to complete the warranty card. It is important that you complete the owner information and return the card to the factory to receive full warranty benefits.

Contents

Preface	3
How this handbook is organised	3
Warranty	3
Safety information	3
EMC conformance	4
Chapter 1: Introduction	1
1.1 Overview	1
1.2 Specification	2
Chapter 2: Basic Operation	3
2.1 Key functions	3
2.2 Display layout	4
2.3 Using Auto mode	5
Engaging the Autopilot (Auto)	5
Disengaging the autopilot (Standby) to return to hand steering	5
Changing course in Auto mode	5
Dodging obstacles in Auto mode	6
Returning to the previous locked heading	6
Automatic tack (AutoTack)	7
AutoTack to starboard	7
AutoTack to port	8
Off course alarm	8
Operating hints	9
Making major course changes	9
Course changes under autopilot control	9
Sailboats in gusty conditions	10
2.4 Using Manual mode	10
2.5 Display and keypad illumination	10

2.6 Data pages	11
Chapter 3: Advanced Operation	13
3.1 Operation in Track mode	13
Initiating Track mode	13
Automatic acquisition	14
Manual acquisition	15
Cross track error	16
Tidal stream compensation	16
Waypoint arrival and advance	17
Arrival	17
Skipping a waypoint	18
Advance	18
Dodges	18
Initiating a dodge manoeuvre	18
Cancelling a dodge manoeuvre	18
Safety	18
Position confirmation at the start of a passage	19
Verifying computed positions	19
Plot frequency	19
Setting waypoints	19
General	19
3.2 Operation in Vane mode (WindTrim)	19
Selecting Vane mode	20
Adjusting the locked wind angle	20
Returning to the previous apparent wind angle	21
Dodges	21
Wind shift alarm	22
Using AutoTack in Vane mode	22
Operating hints	23

3.3 Adjusting autopilot performance	23
Changing the response level (AutoSeastate)	23
Changing the rudder gain	24
3.4 Alarms	24
SeaTalk failure	25
No link	25
Off course	25
Wind shift	25
Large cross track error	25
Drive stopped	25
Data not received	26
Waypoint advance	26
Low battery	26
Watch alarm	27
Man overboard (MOB)	27
Chapter 4: CodeLock	29
4.1 CodeLock Modes	29
4.2 Setting Up CodeLock	29
Initial Setup	29
Changing the code or master unit	31
4.3 Entering your code (Manual mode only)	31
4.4 Code number problems	32
Chapter 5: Customising the System	33
5.1 User setup	33
Compass deviation correction	35
Deviation display	35
Heading alignment	35
Heading mode	35
Bar selection	35

Rudder calibration	36
Data pages	36
5.2 Dealer setup: Type 100/300 Course Computer	38
Recommended settings	39
Pilot type	39
Calibration lock	40
Rudder gain	40
Rate level	40
Rudder offset	41
Rudder limit	41
Turn limit	41
Cruise speed	42
Off course alarm	42
AutoTrim	43
Power steer	43
Drive type	44
Rudder damping	44
Variation	45
AutoAdapt	45
Latitude	46
Wind Trim	46
Tack angle	46
AutoRelease	47
Response	47
Recording calibration settings	47
Chapter 6: Installation	49
6.1 Planning the Installation	49
EMC installation guidelines	49
Connections to other equipment	50
Cabling	50

6.2 Control head	50
Siting	51
Mounting procedure	51
Connections to the SeaTalk bus	52
SeaTalk cables	52
Cable types	52
Typical SeaTalk cabling	53
6.3 NMEA interface	53
Cabling	53
NMEA cable connectors	54
NMEA data transmission	54
Transmission of NMEA data on SeaTalk	55
6.4 Functional test (repeater unit)	55
Switch on	56
Navigation interface (GPS, Decca, Loran)	56
SeaTalk interface	57
Chapter 7: Post Installation Procedures	59
7.1 Functional test and initial calibration	59
Switch on	59
Initial calibration	59
Operating sense	59
Navigation interface (GPS, Decca, Loran)	60
Wind transducer interface	61
SeaTalk interface	61
7.2 Initial sea trial	62
EMC conformance	62
Overview	62
Automatic compass deviation correction	63
Further heading alignment adjustment	65

Checking autopilot operation	66
Checking the rudder gain	66
Chapter 8: Maintenance	69
General	69
Servicing and safety	69
Advice	69
Chapter 9: Fault Finding	71
Index	73

Chapter 1: Introduction

1.1 Overview

The ST6000 Plus is a SeaTalk® compatible autopilot control unit. It is designed for use as a repeater in an autopilot system, allowing autopilot control from a secondary location, or as the control unit for a Type 100/300 Course Computer. It can also repeat instrument data in a programmable selection of Data Pages.

The ST6000 Plus can share all data transmitted from other Raytheon SeaTalk instruments:

- Wind information from a wind instrument can be used for wind trim (Vane) steering without the need to install a separate vane.
- Track information, from a navigation instrument, provides waypoint control from the autopilot.
- Boat speed from the Speed instrument provides optimum track-keeping performance.

The ST6000 Plus autopilot can also be used with any navigator (GPS, Decca, Loran) transmitting NMEA 0183 data.

There are five operating modes:

Standby: Autopilot disengaged

Auto: Autopilot engaged and locked onto a heading

Track: Autopilot maintains a track between two waypoints created using a navigation system

Vane: Autopilot maintains a course relative to an apparent wind angle

Manual: Autopilot power steers rudder using joystick control

When the ST6000 Plus is being used to repeat instrument data, “pop-up pilot” pages are displayed for 5 seconds whenever a change in autopilot control is made.

The ST6000 Plus also provides the following:

- Automatic tack facility, which can be used in Auto and Vane modes
- Automatic compass deviation correction
- Northerly/Southerly heading compensation
- Automatic heading deadband – seastate control
- Waypoint advance feature

- Setup and calibration options to suit each installation, giving maximum performance with many types of boat, with three calibration menus (user, intermediate and dealer)
- Raytheon CodeLock security support

1.2 Specification

- Power Supply: 10 to 15 V dc
- Current consumption:
Standby: 60 mA (less than 200 mA with full lighting)
- Operating temperature: 0°C to +70°C (32°F to 158°F)
- Eight button illuminated digital keypad
- LCD display of heading, locked course and navigational data, with three levels of illumination
- Input connections for SeaTalk and NMEA
- Output connection for SeaTalk

Chapter 2: Basic Operation

This chapter first provides summary diagrams of the key functions and screen layout. It then gives operating instructions for engaging the autopilot and using Auto mode, changing the lighting, and displaying Data Pages.

2.1 Key functions

The autopilot is controlled using simple push-button operations, all of which are confirmed with a beep. In addition to the main single key functions, there are several dual key functions.

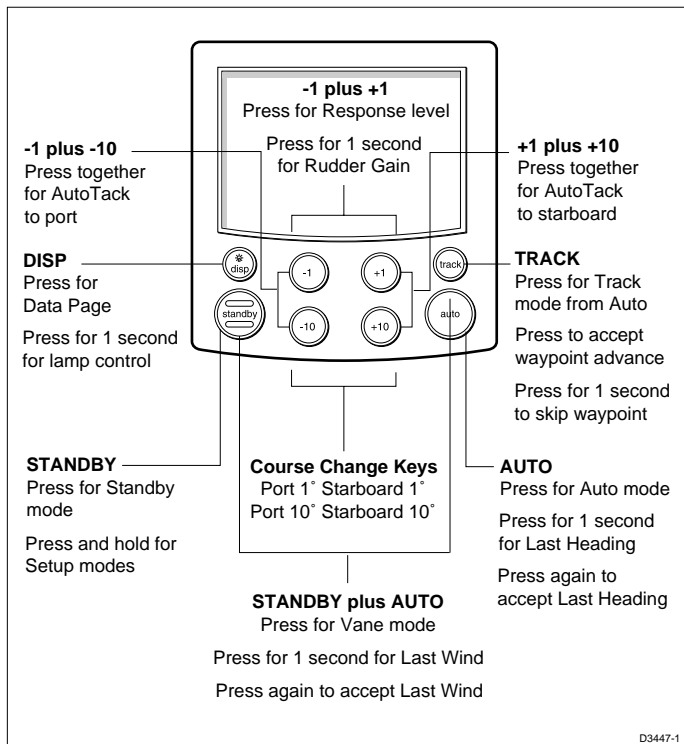

- The autopilot always powers up in Standby mode. (If the text CODE LOCK is displayed, enter your code as described in *Chapter 4*.)
- Course changes can be made at any time using the **-1**, **+1**, **-10** and **+10** keys.
- You can return to manual steering at any time by pressing **standby**.

2.2 Display layout

The following illustration shows all the elements, together with a brief description, that make up the ST6000 Plus autopilot LCD display.

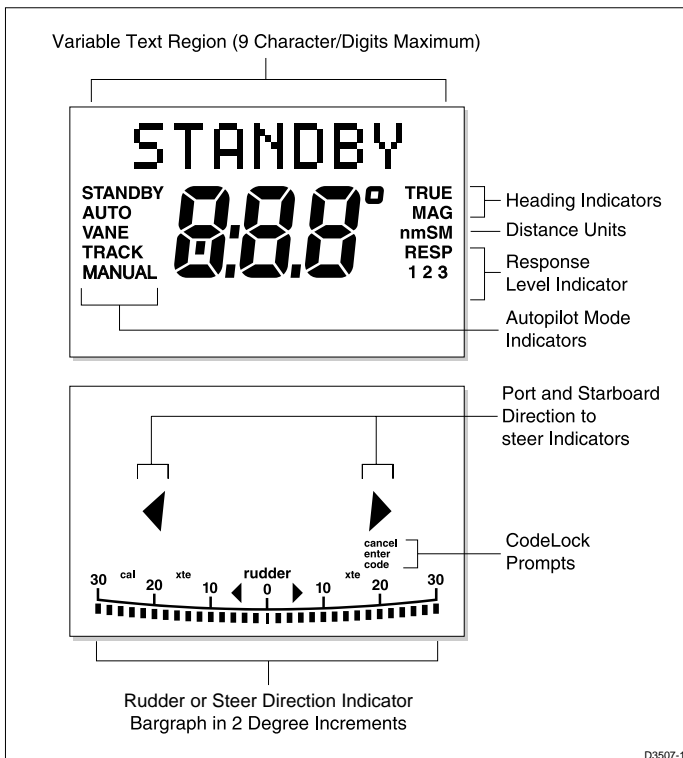

- The bar graph at the bottom of the display is normally a rudder bar. If it has been set as a direction-to-steer indicator, the display depends on the current mode, as follows:

Mode	Bar
Standby	Not used
Auto	Heading error bar
Track	Cross track error (XTE) bar, in 0.02 nm increments
Vane	Wind angle error bar

- If neither distance units (nm or SM) is displayed, the distance is in Km.

2.3 Using Auto mode

Engaging the Autopilot (Auto)

1. Steady the vessel on the required heading.
2. Press **auto**.

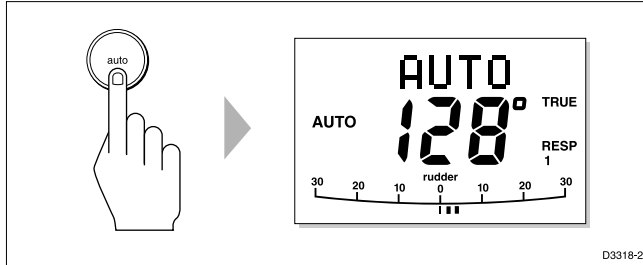

- In Auto mode, the display shows the locked autopilot heading.

Disengaging the autopilot (Standby) to return to hand steering

- Press **standby**.

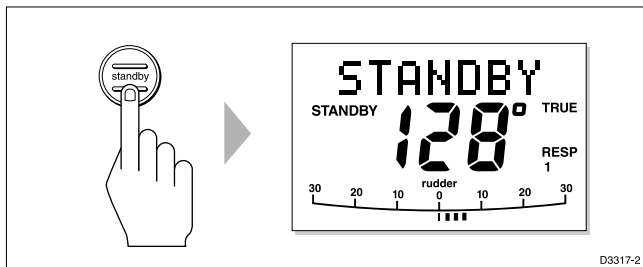

- In Standby mode, the display shows the vessel's current compass heading.
- The previous autopilot heading is memorised and can be recalled (see *Returning to the previous locked heading*).

Changing course in Auto mode

- The **+1** and **+10** (starboard) and **-1** and **-10** (port) keys are used to change the locked heading, in increments of 1° and 10°, when the autopilot has control.

Example: a 30° course change to port = press **-10** three times.

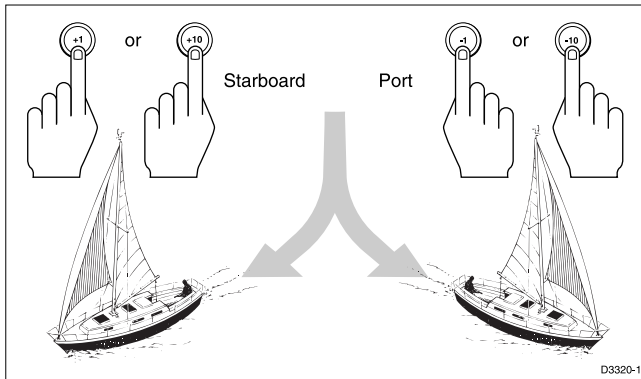

Dodging obstacles in Auto mode

In order to avoid an obstacle when your vessel is under autopilot control, select a course change in the appropriate direction (for example, port 30° = press **-10** three times).

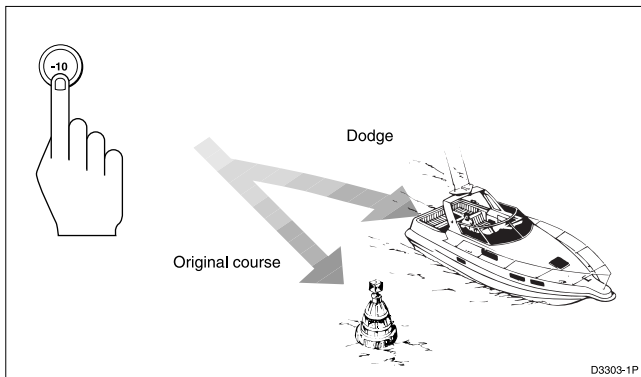

- When safely clear of the obstacle, you can reverse the previous course change (for example, press **+10** three times), or return to the previous locked heading (LAST HDG).

Returning to the previous locked heading (LAST HDG)

If for any reason the vessel is steered away from the selected locked heading (for example, executing a dodge manoeuvre or selecting Standby) you can return to the previous locked heading:

1. Press **auto** for 1 second. The previous locked heading (LAST HDG?) is displayed for 10 seconds.

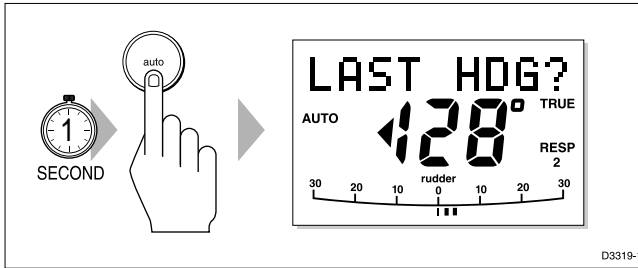

Note: A direction-to-steer indicator is displayed to show you the direction the vessel will turn.

2. To accept this heading, and resume the original course, press **auto** once within this 10 second period.

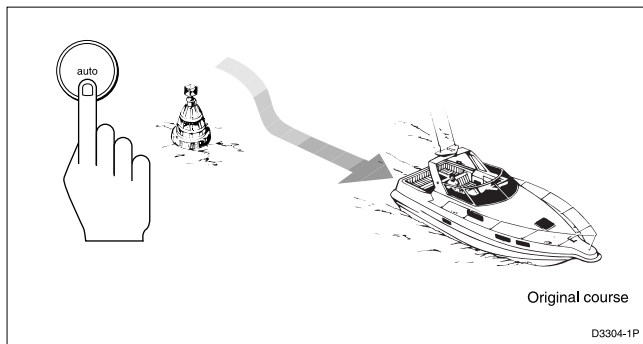

If you do not press **auto** while the display is flashing, the current heading will be maintained.

Automatic tack (AutoTack)

The ST6000 Plus has a built in automatic tack facility that turns the vessel through a predetermined angle (the factory default is 100°) in the required direction.

AutoTack to starboard

- Press the **+1** and **+10** keys together to tack to starboard.

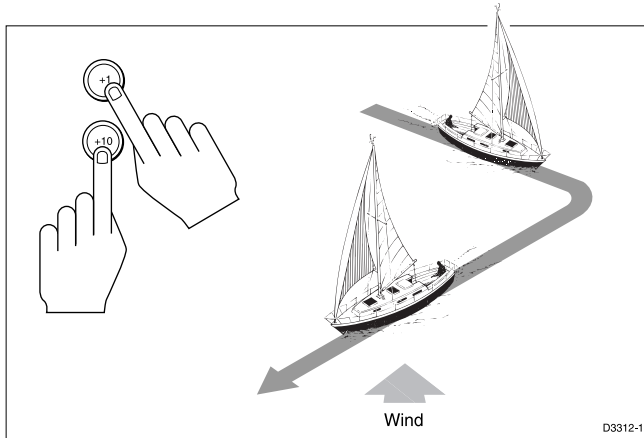

AutoTack to port

- Press the **-1** and **-10** keys together to tack to port .

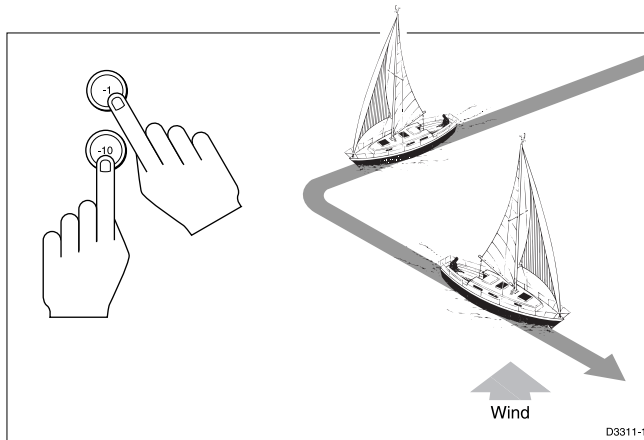

Off course alarm

The off course alarm will sound if the locked autopilot heading and the vessel's current heading differ for more than 20 seconds, by more than the alarm angle set in calibration (the factory default is 20°).

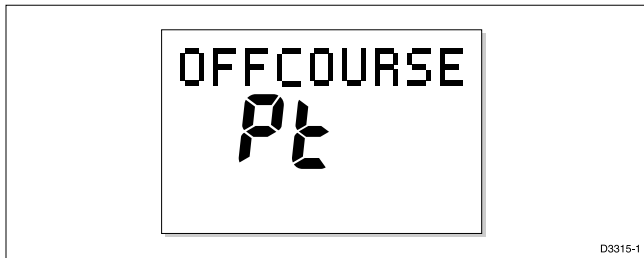

1. To cancel the off course alarm, press **standby** to return to hand steering.
2. Check whether your vessel is carrying too much sail, or whether the sails are badly balanced. Significant improvements in course keeping can usually be obtained by improving sail balance.

Operating hints

Making major course changes

- It is sound seamanship to make major course changes only when steering manually.
- Manual course changes ensure that obstructions or other vessels can be cleared properly, and due account taken of the changed wind and sea conditions on the new heading prior to engaging the autopilot.

Course changes under autopilot control

It is important to understand the effect of sudden trim changes on steering performance. When a sudden trim change occurs, due, for example, to weather helm or sail imbalance, there will be a delay before the automatic trim applies rudder to restore the locked heading. This correction can take up to one minute.

Large course changes which change the apparent wind direction can produce large trim changes. In these situations, the autopilot will not immediately assume the new automatic heading, and will only settle onto course when the automatic trim has been fully established.

To eliminate this problem, the following procedure can be adopted for large course changes:

1. Note the required new heading.
2. Select **standby** and steer manually.
3. Bring the vessel onto the new heading.

4. Select **auto** and let the vessel settle onto course.
5. Bring the vessel to the final course with 1° increments.

Sailboats in gusty conditions

In gusting conditions, the course may tend to wander slightly, particularly if the sails are badly balanced. A significant improvement in course keeping can always be obtained by improving sail balance. Bear in mind the following important points:

- Do not allow the yacht to heel over excessively
- Ease the mainsheet traveller to leeward to reduce heeling and weather helm
- If necessary, reef the mainsail a little early

It is also advisable, whenever possible, to avoid sailing with the wind dead astern in very strong winds and large seas.

Ideally, the wind should be brought at least 30° away from a dead run and, in severe conditions, it may be advisable to remove the mainsail altogether and sail under headsail only.

Provided these simple precautions are taken, the autopilot will be able to maintain competent control in gale force conditions.

2.4 Using Manual mode

If your system is fitted with a joystick, the ST6000 Plus will enter Manual mode when the joystick is used.

The ST6000 Plus will return to Standby mode when the joystick button is released, or if you press the **standby** key on the ST6000 Plus.

2.5 Display and keypad illumination

- Press **disp** for 1 second, from any mode, to enter illumination adjustment mode and turn the lights on.
- Subsequent presses of the **disp** key cycles the possible illumination settings: L3, L2, L1, OFF, L1, L2, L3 etc. where L3 is the brightest setting.

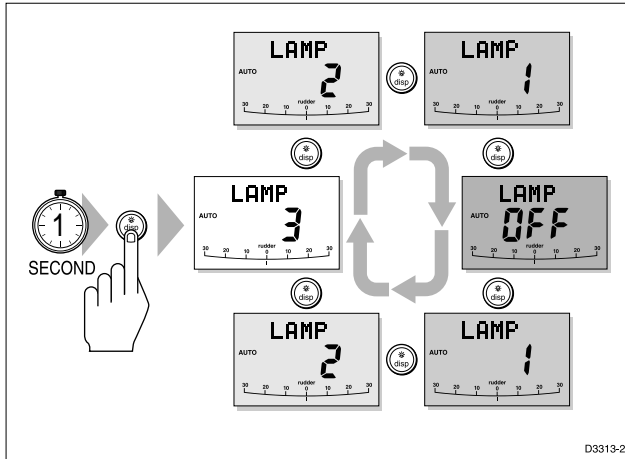

The display times out to normal operation after 10 seconds of keypad inactivity.

Pressing any other key before the 10 second time-out will select the mode assigned to that key (for example, **auto** selects Auto mode, **standby** selects Standby mode).

Note: *If other SeaTalk instruments or autopilot control units are connected to SeaTalk, the illumination can be adjusted from these units.*

Any adjustments to the illumination are lost when the unit is switched off.

The keys are still lit at a courtesy level when the display lighting is off.

2.6 Data pages

The **disp** key is used to cycle “pages” of SeaTalk or NMEA data. Once a Data Page is selected, this page becomes the principle autopilot display. The autopilot mode displays (Standby, Auto, Track Vane and Manual) then become “pop-ups”, and are displayed for 5 seconds when the autopilot mode is changed or a course change is made.

- Press **disp** to display each Data Page in turn.
- When the last Data Page is cycled, the display returns to the current autopilot mode display (for example, Standby).
- To return to a previous Data Page, press **disp** for 1 second within 2 seconds of displaying a page. You can continue to move backwards through the Data Page sequence in this way.

Up to 7 Data Pages are available using the **disp** key. The number of pages, and the information displayed on each page, depends on the selections made in User Setup (see section 5.1).

The following illustration shows the default settings for the Data Pages.

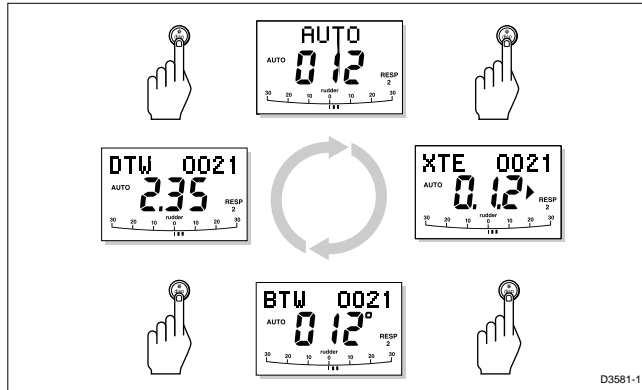

- If the required data for a page is not available, dashes are displayed instead of a value.
- Most displays are repeated data, and cannot be adjusted. The exceptions are the Response and Rudder Gain pages (if selected for display), which can be adjusted using the **+1** and **-1** keys.
- The current autopilot mode is shown at the left of the display, and the autopilot bar graph remains in use.
- The “direction-to-steer” arrows relate to the Data Page information.

Chapter 3: Advanced Operation

This chapter provides information on:

- Operation in Track mode
- Operation in Vane mode (WindTrim)
- Adjusting the response level and rudder gain
- Alarms

3.1 Operation in Track mode

Track mode is used to maintain a track between two waypoints created on a GPS, Decca, or Loran navigation system. The ST6000 Plus will then compute any course changes to keep your boat on track, automatically compensating for tidal streams and leeway.

The ST6000 Plus can receive cross track error (the distance your vessel is from a planned track) from:

(a) A SeaTalk navigation instrument or chartplotter

or

(b) A non-SeaTalk navigation system transmitting data in the NMEA 0183 format – this can be connected directly to the ST6000 Plus NMEA input, as described in the Installation Chapter).

Track mode is selected by pressing the **track** key, but can only be selected from Auto mode. You can return to either Auto or Standby mode from Track mode, as follows:

- Press **auto** to leave Track mode and return to Auto mode.
- Press **standby** to leave Track mode and return to manual steering.

Note: *The ST6000 Plus control head can be programmed to display various pages of navigation data, such as XTE, BTW etc. Please refer to page 37 for details.*

Initiating Track mode

When initiating Track mode, the track can be acquired in one of two ways:

- Automatic acquisition, when cross track error and bearing to waypoint data are available
- Manual acquisition, when cross track error is the only available data

Automatic acquisition

Automatic acquisition can only be achieved if the pilot is receiving cross track error and bearing to waypoint information (via SeaTalk or NMEA 0183). It is initiated as follows:

1. Bring the vessel to within 0.1nm of track
2. Press **auto**.
3. Press **track** to enter Track mode, with the current locked heading displayed.

After a short delay for data acquisition, the Waypoint Advance alarm will sound, and the display will show the planned bearing to waypoint alternating with the direction in which the boat will turn.

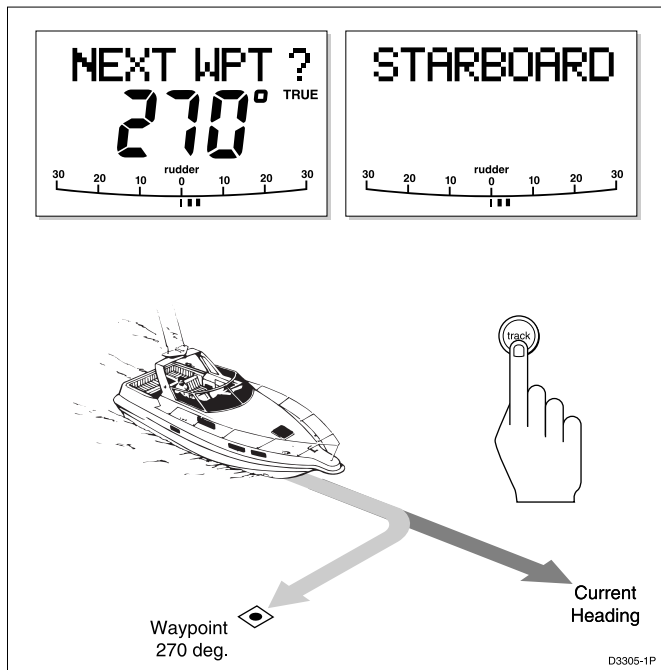

Note: If the vessel is further than 0.3nm from the track, the Large Cross Track Error alarm will sound. Press **standby** to cancel the alarm, hand steer closer to the track, and press **auto** and **track** again.

4. Check that it is safe to turn onto the new course.
5. Press the **track** key. The boat will turn on to the new course and the alarm will be cancelled.

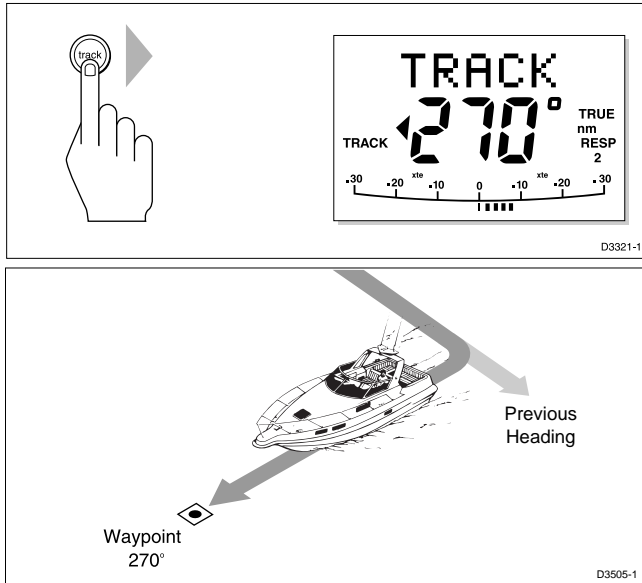

- The display shows the new bearing to waypoint.

Manual acquisition

For manual track acquisition, when only cross track error data is available:

1. Steer the vessel to within 0.1nm of track.
2. Bring the heading to within 5° of the bearing to the next waypoint.
3. Press **auto**.
4. Press **track** to enter Track mode.

- The display shows the locked pilot heading.

Note: *At low speeds, the effect of tidal streams is far more significant than it is at higher speeds. Providing the tidal flow is less than 35% of the vessel's speed, no noticeable difference should occur in the performance of Track mode. However, extra care should be taken during manual acquisition, as follows:*

- *Ensure that the vessel is as close as possible to track, and the direction made good over the ground is as close as possible to the direction of the next waypoint, before selecting Track mode.*
- *Make positive positional checks at regular intervals, especially if navigational hazards are close by.*

Cross track error

Cross track error (XTE) is the distance between the current position and a planned route. This is displayed in nautical miles (nm), statute miles (SM) or kilometres, and is taken directly from your navigator.

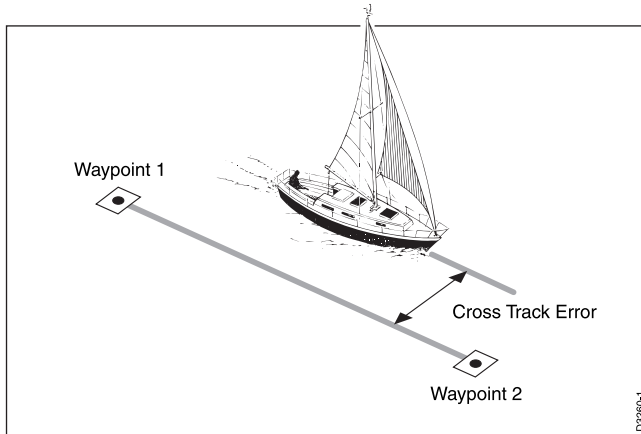

The Large XTE alarm sounds if the XTE exceeds 0.3nm.

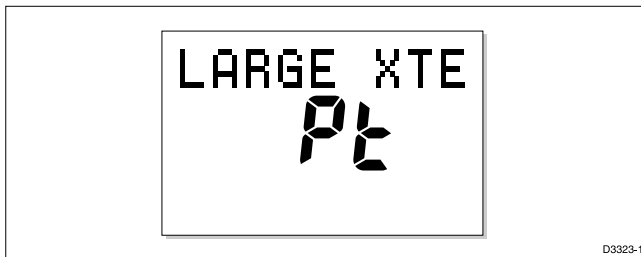

- The direction of the error is identified as “**Pt**” port or “**Stb**” starboard.
- To cancel the alarm and leave track mode, press **standby** to return to hand steering, or **auto** to return to Auto mode.

***Note:** If the Large Cross Track Error alarm sounds, it is usually an indication that the cross tide is too great for the vessel’s current speed.*

Tidal stream compensation

Under most conditions, Track mode will hold the selected track to within ± 0.05 nm (300 ft) or better. The autopilot takes account of vessel speed when computing course changes to ensure optimum

performance over a wide range of vessel speeds. If speed data is available, the ST6000 Plus uses the measured vessel speed. Otherwise, the Speed Over Ground (SOG) or specified cruise speed is used, depending on the calibration setting (see *Dealer Setup* in *Chapter 5*).

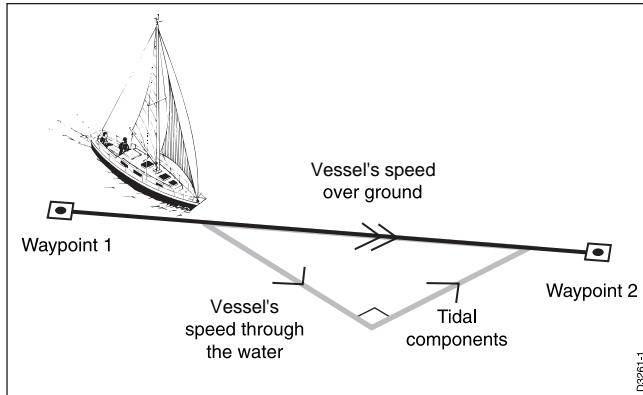

Waypoint arrival and advance

If your navigation receiver transmits valid NMEA waypoint number and bearing to waypoint data, it is possible to advance from one waypoint to the next by simply pressing **track** (only the last four characters of waypoint names are recognized and, therefore, adjacent waypoint names must be different.)

Arrival

As the vessel passes the target waypoint, the navigation receiver should select (manually or automatically) the next target waypoint.

The ST6000 Plus detects the new target waypoint number, sounds the Waypoint Advance alarm and displays the Waypoint Advance information. This display shows the new bearing to waypoint and the direction the boat will turn to acquire the new track.

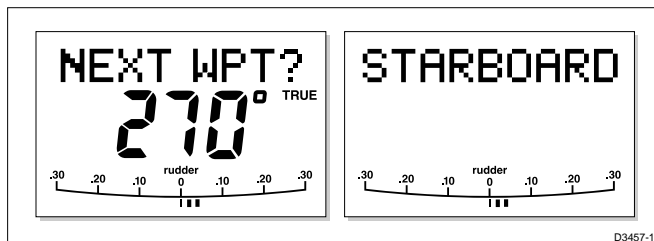

To accept the new target waypoint, press **track**.

Skipping a waypoint – SeaTalk navigators only

If you wish to advance to the next waypoint before you have arrived at the target waypoint, press **track** for 1 second. The Waypoint Advance information for the next waypoint is displayed.

Advance

While the waypoint advance alarm is sounding, Track mode is suspended and the ST6000 Plus maintains the current boat heading.

1. Check that it is safe to turn onto the new track.
2. Press the **track** key. This will cancel the waypoint arrival alarm and turn the boat towards the next waypoint.

Unless the Waypoint Advance is accepted in the above manner, the alarm will continue to sound and the current heading will be maintained.

Dodges

Full control is still available from the keypad when the autopilot is in Track mode.

Initiating a dodge manoeuvre

In track mode, dodge manoeuvres are accomplished by simply selecting the desired course change using the course change keys (-1, +1, -10 or +10).

Cancelling a dodge manoeuvre

Once the hazard has been avoided, the course change selected for the dodge manoeuvre should be cancelled by selecting an equal course change in the opposite direction.

Note: *Provided the vessel remains within 0.1 nm of track, there is no need to steer back towards the track.*

Safety

Passage making in Track mode removes the chores of compensating for wind and tidal drift, and will aid precise navigation. However, it is important to maintain an accurate log with regular plots.

Position confirmation at the start of a passage

At the start of a passage you must always confirm the fix given by the position transducer, using an easily identifiable fixed object. Check for fixed positional errors and compensate for them.

Verifying computed positions

- Verify the computed position with a dead reckoned position, calculated from the average course steered and the distance logged.

Plot frequency

- In open water, plots should be at least hourly.
- In confined waters, or when potential hazards are near, plots should be more frequent.
- Local variations in radio signal quality, and changes in the tidal stream, will produce deviations from the desired track.

Setting waypoints

- When setting waypoints, remember that deviations will occur.
- Thoroughly check along each track.
- Check up to 0.5 nm each side of the track to ensure that there are no hazards within the zone.

General

The use of track mode will enable accurate track keeping even in complex navigational situations. However, it cannot remove the responsibility of the skipper to ensure the safety of his vessel at all times by careful navigation and frequent position checks.

3.2 Operation in Vane mode (WindTrim)

Vane mode, also known as WindTrim, allows the ST6000 Plus to maintain a course relative to an apparent wind angle. It uses wind trim to eliminate the effects of turbulence and short term wind variations, and provides smooth precise performance under Vane mode operation with minimal power consumption.

Vane mode uses the fluxgate compass as the primary heading reference and, as changes in the apparent wind angle occur, the locked compass heading is adjusted to maintain the original apparent wind angle.

To use Vane mode, the ST6000 Plus must receive wind information from one of the following sources:

- SeaTalk Wind instrument, connected to a ST6000 Plus via SeaTalk
- NMEA wind information
- Raytheon wind vane connected to a SeaTalk interface box

Selecting Vane mode

Vane mode can be selected from either Standby or Auto modes, as follows:

1. Steady the vessel onto the required apparent wind angle.
2. Press **standby** and **auto** together to select Vane mode and lock the current apparent wind angle.

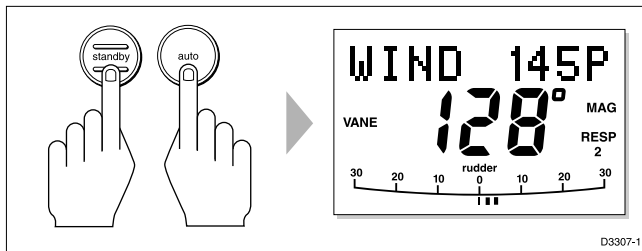

- The locked heading is displayed along with the apparent wind angle.
- The boat heading is adjusted by the pilot to maintain the locked apparent wind angle.

Adjusting the locked wind angle

The locked wind angle can be adjusted by changing course using the **-1**, **+1**, **-10** and **+10** keys.

For example, to bear away by 10° when the vessel is on starboard tack, press **-10** to turn the vessel 10° to port. The locked apparent wind angle and locked heading both change by 10°. The new apparent wind angle is maintained, and the locked heading adjusted by the autopilot as required.

Note: This method should only be used for minor adjustments to the apparent wind angle, since turning the boat affects the relationship between the true and apparent wind angles. For major changes, return to Standby mode, steer onto the new heading, and reselect Vane mode.

Returning to the previous apparent wind angle (LAST WND)

If for any reason the vessel is steered away from the selected apparent wind angle (for example, a dodge manoeuvre or selecting Standby) you can return to the previous locked wind angle:

1. Press **standby** and **auto** together for 1 second to display the previous apparent wind angle (LAST WND?).

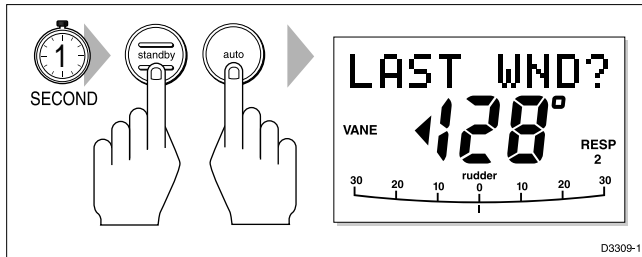

The LAST WND? text alternates with the previous wind angle and direction. The previous locked heading is displayed, with an indicator to show you the direction in which the vessel will turn.

2. Check that it is safe to turn on to this course.
3. To accept this apparent wind angle, press **standby** and **auto** together within 10 seconds.

If you do not accept the previous wind within this time, the autopilot will lock on to the current apparent wind angle.

Dodges

Full control is still available from the keypad when the autopilot is in Vane mode.

- Dodge manoeuvres are accomplished by simply selecting the desired course change using the course change keys (-1, +1, -10 or +10). Both the locked heading and locked apparent wind angle are adjusted.
- Once the hazard has been avoided, you can reverse the previous course change, or return to the previous apparent wind angle (LAST WND).

Wind shift alarm

The wind shift alarm sounds, and the text WINDSHIFT is displayed, if a wind shift of more than 15° is detected.

1. Press **standby** to cancel the alarm and return to hand steering, and steer onto the required heading.
2. Press **standby** and **auto** together to return to Vane mode with the new apparent wind angle.

Using AutoTack in Vane mode

The automatic tack function tacks the vessel through a set angle (the factory default is 100°). The locked heading can then be adjusted until the required apparent wind angle is achieved.

- To tack to starboard, press the **+1** and **+10** keys together.
- To tack to port, press the **-1** and **-10** keys together.

Note: *If you use the Autotack function in Vane mode, it is important to check that the wind vane has been centred accurately when it was installed.*

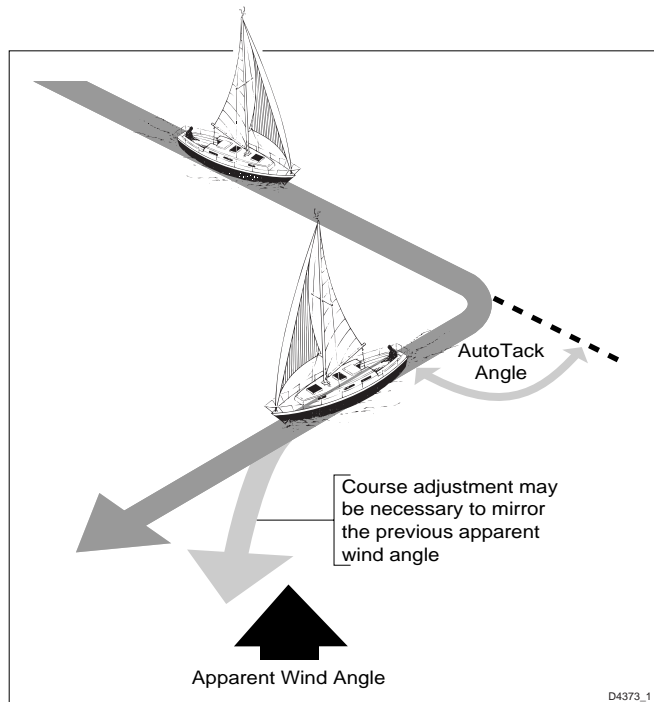

Operating hints

- Major changes to the selected apparent wind angle should be made by returning to Standby mode, changing course manually, then reselecting Vane Mode.
- Vane mode filters the windvane output. This provides the optimum response for off-shore conditions where genuine shifts in wind direction occur gradually.
- In gusty and unsteady inshore conditions, it is best to sail a few degrees further off the wind so that changes in apparent wind direction can be tolerated.
- It is important to ensure that the amount of standing helm is minimised by careful sail trimming and positioning of the mainsheet traveller.
- The headsail and mainsail should be reefed a little early rather than too late.

3.3 Adjusting autopilot performance

The response level and rudder gain can be adjusted during normal operation using a combined key-press. Alternatively, you can set up these two control displays as default Data Pages (see section 2.5).

The default calibration settings for response and rudder gain (refer to Dealer Setup) are restored when the system is powered on.

Changing the response level (AutoSeastate)

The response level controls the relationship between the autopilot's course keeping accuracy and the amount of helm/drive activity.

- **Response Level 1**, AutoSeastate (Automatic Deadband), causes the autopilot to gradually ignore repetitive movements of the vessel and only react to true variations in course. This provides the best compromise between power consumption and course keeping accuracy, and is the default calibration setting.
- **Response Level 2** (Minimum Deadband) provides the tightest course keeping possible. However, tighter course keeping results in increased power consumption and drive unit activity.
- **Response Level 3** (also Minimum Deadband) provides the tightest course keeping possible by introducing yaw damping.

The response can be changed at any time. To do so:

1. Press the **+1** and **-1** keys together momentarily to display the RESPONSE screen.
2. Press **+1** or **-1** to change the response level.
3. Wait for 10 seconds, or press **disp**, to return to the previous display.

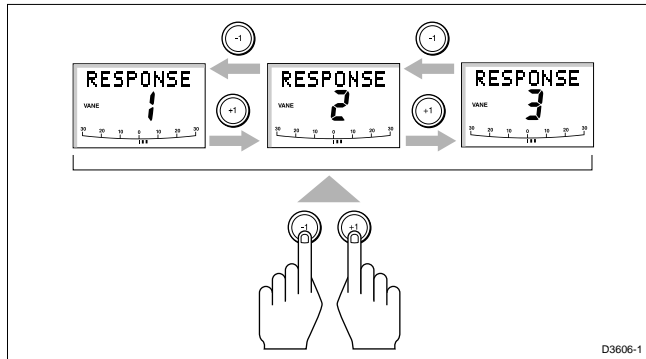

Changing the rudder gain

Press the **+1** and **-1** keys together for 1 second to display the Rudder Gain screen, and adjust the setting in the same way as for the response level. Refer to *Chapter 7, Post installation procedures*, for instructions on how to check that the rudder gain is set correctly.

WARNING:

It is important that the rudder gain is correctly set on planing craft. Incorrect adjustment will lead to poor steering performance and is dangerous at high speeds.

3.4 Alarms

This section summarises the alarms (in order of priority) that are reported by the ST6000 Plus.

Press **standby** to clear an alarm and return to hand steering, unless indicated otherwise.

SeaTalk failure

ST FAIL

This silent alarm indicates that there is a wiring fault in the SeaTalk connection.

No link

NO LINK

This silent alarm indicates that there is no link between the ST6000 Plus and the course computer.

Off course

OFFCOURSE

This alarm is activated when the vessel has been off course from the locked heading by more than the specified angle for more than 20 seconds (see section 2.3, *Using Auto mode*).

The alarm is cleared if the heading recovers or the course is changed, or if the operating mode is changed.

Wind shift

WINDSHIFT

This alarm is activated when a change in the apparent wind angle requires an adjustment of the locked heading by more than 15° (see section 3.2, *Operation in Vane mode*).

Large cross track error

LARGE XTE

This alarm is activated when the cross track error exceeds 0.3 nm (see section 3.1, *Operation in Track mode*).

The alarm is cleared if the heading recovers or the course is changed, or if the operating mode is changed.

Drive stopped

DRIVESTOP

This alarm is activated if the autopilot is unable to turn the rudder. This occurs if the weather load on helm is too high, or if the requested rudder position is past the pre-set rudder limits or the rudder end-stops.

Data not received

NO DATA

This alarm is displayed in the following circumstances:

- Track mode is engaged and the autopilot is not receiving SeaTalk navigation data.
- Track mode is engaged and the position transducer (GPS, Loran, Decca) is receiving a low strength signal – this will clear as soon as the signal strength improves.
- Vane mode is engaged and the autopilot has not received wind angle data for 30 seconds.

The autopilot stops adjusting the locked heading as soon as data is lost.

Waypoint advance

NEXT WPT?

The waypoint advance alarm sounds whenever the target waypoint number changes, which occurs in the following circumstances:

- Automatic acquisition is selected by pressing **track** from Auto mode
- Waypoint arrival. Vessel arrives at the target waypoint and moves onto the next waypoint in the route.
- Waypoint advance is requested by pressing **track** for 1 second in Track mode (SeaTalk Navigators only).

When the alarm sounds, the pilot continues on its current heading, but displays the bearing to the next waypoint and the direction in which the boat will turn to take up that bearing.

Check that it is safe to turn onto the new track, and press **track** to accept the waypoint advance.

To cancel the alarm without accepting the waypoint advance, press **standby** to return to hand steering, or **auto** to return to Auto.

***Note:** The waypoint advance will only operate on pilots receiving valid bearing to waypoint and waypoint number information.*

Low battery

LOW BATT

The Low Battery alarm sounds when the supply voltage drops below acceptable limits.

Press **standby** to clear the alarm and return to hand steering.

Start the engine to recharge the battery.

Watch alarm

WATCH ALM

The Watch alarm is activated in Watch mode when the timer reaches 4 minutes. It is not available from Standby mode.

If you wish to set the Watch mode, the WATCH screen must be configured as one of the Data Pages for display, as described in section 5.1.

To set and control the Watch alarm:

1. Select Auto, Track or Vane mode.
2. Press the **disp** key until the WATCH Data Page is displayed.
 - The watch timer starts counting.
 - When the timer reaches 3 minutes, the text on the display starts flashing to indicate the last minute of Watch alarm.
 - When the timer reaches 4 mins, the audible Watch alarm activates.
3. Press **auto** at any time to silence the alarm and reset the timer to 4 minutes. (Pressing any other key resets the timer and perform the key's normal function.)
4. To clear Watch mode, press **disp** to display a different page, or press **standby**.

Note: *You cannot engage Auto mode from Watch mode – pressing **auto** only resets the Watch timer.*

Man overboard (MOB)

If a man overboard (MOB) message is received from another instrument on the SeaTalk system, the text MOB is shown instead of the waypoint number for the XTE, DTW and BTW Data Pages.

If the autopilot is operating in Track mode, the Waypoint Advance alarm will sound to notify the change in waypoint.

Chapter 4: CodeLock

CodeLock is a personal four-digit security feature designed to protect your valuable instruments against theft. You don't have to activate the system, but it's there if you need to. You can activate it using any CodeLock-compatible control unit on your SeaTalk system.

When you first enter a code and activate CodeLock, the code is sent to all the CodeLock-compatible units on the system. After this, whenever you power on the system, the units will only start up if they receive the correct code.

Remember to fix a CodeLock sticker by each instrument, to deter potential thieves.

4.1 CodeLock Modes

When you set up CodeLock, you can choose whether the code will be sent automatically or must be entered manually at power on, as follows:

- **Auto** mode is used when there is a display unit situated in a secure location, ideally below deck, or one which can be unplugged and removed to a secure location. You enter your chosen code on this "master" unit when you first activate CodeLock. This code is then automatically sent to all CodeLock-compatible display heads on SeaTalk, without further intervention, every time the system is powered on.
- **Manual** mode is used to provide a higher degree of security, perhaps when all your instruments are mounted in exposed locations. In this case, you must enter your personal code every time the system is switched on. The code can be entered into any convenient CodeLock-compatible control unit, and is then sent to all the other compatible units via SeaTalk.

4.2 Setting Up CodeLock

CodeLock is set up and activated on the ST6000 Plus using the Intermediate Setup options.

Initial Setup

When you first install your ST6000 Plus, CodeLock is set OFF. To activate CodeLock, refer to the flow diagram on the next page.

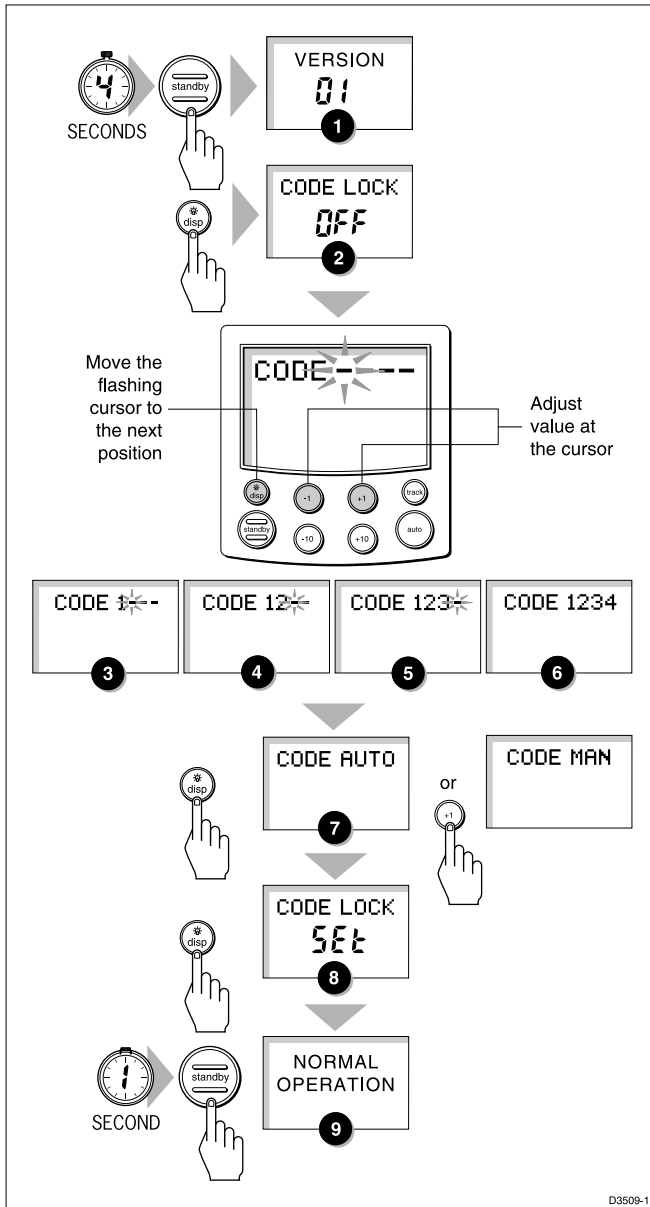

- Make sure that the autopilot is in Standby mode before accessing Intermediate Setup.
- If the CAL LOCK screen is displayed instead of the VERSION screen, you need to turn off the lock feature in Dealer Setup.

The Intermediate Setup displays have the following functions:

- **Version numbers:** Displays the current ST6000 Plus version number, alternating with the Course Computer version number (if applicable). You cannot adjust these displays.
- **CodeLock status:** Reports the current status, which can be OFF or SET. You cannot adjust this display directly.
- **CodeLock entry:** Used to enter a new code if CodeLock is OFF, or to turn CodeLock off if it is already set.
- **CodeLock mode:** Used to select Auto or Manual CodeLock mode, when a new code has been entered.

Changing the code or master unit

You can change the code from any CodeLock compatible control unit on your SeaTalk system, provided you know the current code.

Note: If you set up CodeLock in Auto mode, the unit on which you enter the new code becomes the new master unit.

To change the code:

1. Display the CodeLock entry screen and enter your current code, as shown in the flowchart.
The code is checked. If it is incorrect, the four dashes are redisplayed and you must enter the code again. If it is correct, the CodeLock status screen is displayed, with the status set to OFF.
2. Press **disp** to display the CodeLock entry screen again.
3. Enter the new code and move on to the CodeLock mode selection screen.
4. Set the mode to Auto or Manual, as required.
5. Press and hold **standby** for 1 second to exit Intermediate Setup and save the new settings.

4.3 Entering your code (Manual mode only)

If CodeLock has been set up in Manual mode, the correct code must be entered on one of the control units every time the system is switched on. The code number created on the master is entered via the keypad from any CodeLock-compatible instrument, and this code is then sent to all compatible instruments on the same SeaTalk bus. Once this code has been received the instruments operate in the normal way.

To enter your chosen code number on the ST6000 Plus display unit, use the keys as shown.

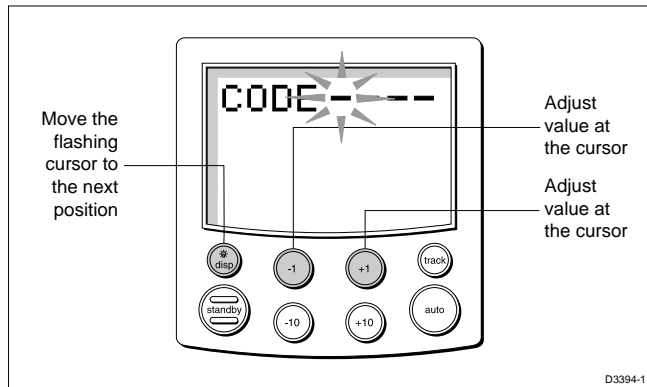

To enter the code on any other master display unit, refer to the handbook for that unit for details of the code entry procedure.

4.4 Code number problems

- If an incorrect code number has been entered, the four dashes are redisplayed, with the prompt “enter code”. Repeat the procedures illustrated above entering the correct four digit number.
- If you forget your code number, you must take your master unit to an authorised dealer, together with appropriate proof of ownership such as the original invoice. The dealer will be able to reset the unit so that you can enter a new code.

Chapter 5: Customising the System

The ST6000 Plus provides setup and configuration options that are used to adjust the settings for the ST6000 Plus itself, the compass, and the autopilot.

Note: *You should perform the post installation procedures described in Chapter 7 before adjusting any other calibration features.*

There are three setup levels:

- **User Setup**, which controls compass setup, rudder calibration and the ST6000 Plus display features
- **Intermediate Setup**, which controls the CodeLock security feature and displays status and version number information (see *Chapter 4*)
- **Dealer Setup**, which controls the autopilot settings, and also the calibration lock which can be used to prevent accidental access to User and Intermediate Setup

The Dealer Setup options described in this chapter only apply if you have installed the ST6000 Plus as the control unit for a Type 100/300 course computer. If you have installed the ST6000 Plus as a repeater unit on an autopilot system, please refer to the Dealer Setup instructions in the handbook for the main control unit.

Note: *If the vessel type is changed, you must then relinearise the fluxgate compass.*

If an ST4000/5000 control unit is used, please refer to the appropriate manual for system calibration.

5.1 User setup

The flow chart on the following page shows the User Setup control procedure, and the setup screens with their default settings. Information on the functions of the different settings is given in the remainder of this section.

The following points should be considered:

- Make sure that the autopilot is in Standby mode before you access User Setup
- If the CAL LOCK screen is displayed instead of the initial page, you need to turn off the lock feature in Dealer Setup
- Setup options are always saved on exit



SETUP

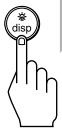

SWING
COMPASS?
OFF



DEVIATION
0°



HDG ALIGN
000°



HDG MAG
◀ ▶



RUDD BAR
◀ ▶
-20 -10 0 10 20
rudder



DOCKSIDE
RUDD CAL
OFF



DATA PAGE
◀ 1 ▶



Adjusting User Setup Values

Returning to a Previous Setup Display

Within 2 seconds of the new display appearing

Quitting User Setup

Note:
The 'Dockside Rudder Calibration function automatically calibrates rudder range on systems fitted with a rudder reference unit. If a rudder reference unit is not installed, the function determines the helm drive speed.

Compass deviation correction (SWING COMPASS)

The compass deviation correction option allows you to correct the compass for deviating magnetic fields. The procedure must be performed as the first item in your initial sea trial, and is described in detail in *Chapter 7, Post Installation Procedures*.

Deviation display (DEVIATION)

The deviation screen shows the current deviation value, calculated from the correction procedure (Swing Compass). You cannot edit this value.

Heading alignment (HDG ALIGN)

The heading alignment screen shows the current reported heading.

Note: *You should always check the compass alignment after performing a compass deviation correction (see Post Installation Procedures). However, once the initial correction procedure has been performed, you can make adjustments to the alignment as often as you wish, without re-correcting your compass.*

- Steer your vessel onto a known heading, and check the heading displayed.
- If required, adjust the heading value to match the known value, using the **+1**, **-1**, **+10** and **-10** keys.

Heading mode (HDG)

Select either magnetic or true heading mode. When heading data is displayed in normal operation, the screen indicates whether true or magnetic mode has been selected.

Bar selection (RUDD BAR)

Select the type of bar graph that is shown at the bottom of the SeaTalk displays. The options are as follows:

RUDD BAR: This shows the rudder position, and is the default setting. Note that a rudder reference transducer is required for accurate rudder position information.

STEER BAR: The bar graph is used as follows:

Mode	Bar
Standby	Not used
Auto	Heading error bar
Track	XTE bar
Vane	Wind angle error bar

Rudder calibration (DOCKSIDE RUDD CAL)

The Dockside Rudder Calibration function performs an automatic calibration of the rudder range, for systems with a rudder reference unit. If a rudder reference unit is not installed, the function determines the helm drive speed.

WARNING:

This procedure moves the helm, and should only be used when the vessel is at the dockside. For sterndrive systems, the engines must running before you start the procedure.

The auto dockside procedure is not available if the ST6000 Plus is used with a Type 100/300 Course Computer.

If you start the procedure by mistake, press any key to cancel it.

Data pages (DATA PAGE)

The next 7 pages of User Setup allow you change the default settings for the Data Pages. These are the pages of SeaTalk or NMEA data available for display using the **disp** key during normal operation (see section 2.5).

Each of the setup pages initially shows the title DATA PAGE. After 1 second, this changes to show the title of the data currently set for that page.

The available pages are as follows:

Data	Displayed as
Speed Knots	SPEED KTS
Log	LOG XXXX.X
Trip	TRIP XXX.X
Average Speed, Knots	AV. SPD KTS
Wind Direction	E.g. WIND PORT
Wind Speed	WIND KTS
Depth Metres	DEPTH M
Depth Feet	DEPTH FT
Depth Fathoms	DEPTH FA
Heading	HEADING
Water Temperature, Degrees C	WATER °C
Water Temperature, Degrees F	WATER °F
Course Over Ground	COG
Speed Over Ground, Knots	SOG KTS
Cross Track Error	XTE
Distance to	WaypointDTW
Bearing to Waypoint	BTW
Rudder Gain	RUDD GAIN
Response	RESPONSE
Watch	WATCH
Universal Time Constant	UTC

The default pages are:

Data Page	Default Setting	Sequence Number
1	XTE Cross Track Error	12
2	BTW Bearing to Waypoint	14
3	DTW Distance to Waypoint	13
4	NOT USED	19
5	NOT USED	19
6	NOT USED	19
7	NOT USED	19

- For each setup page, scroll forwards or backwards using the **+1** or **-1** keys, until the required page title is displayed.

Notes: *If you set a page to NOT USED, it is omitted from the display cycle during normal operation. For example, with the default page settings only three pages are displayed in the sequence.*

There are 3 depth pages and 2 water temperature pages. Data is displayed in the units defined by the selected page.

- Press **disp** to move on to the next Data Page selection screen, and repeat the selection procedure.

Note: *If a man overboard (MOB) message is received by the autopilot, the BTW and DTW pages will display the bearing and distance to the MOB location, so it is good practice to retain these pages for display.*

5.2 Dealer setup: Type 100/300 Course Computer

This section applies if you have installed the ST6000 Plus as the control unit for a Type 100/300 Course Computer. If you are using the ST6000 Plus as a repeater for another autopilot system, refer to the Dealer Setup instructions in the handbook for the main control unit.

Dealer Setup is used to customise the autopilot to your boat. However, once the Pilot Type is set, the factory defaults will provide safe performance for initial sea trials, and fine tuning is not normally required. The flow chart below shows you how to enter Dealer Setup, scroll through the setup displays, adjust the values and exit.

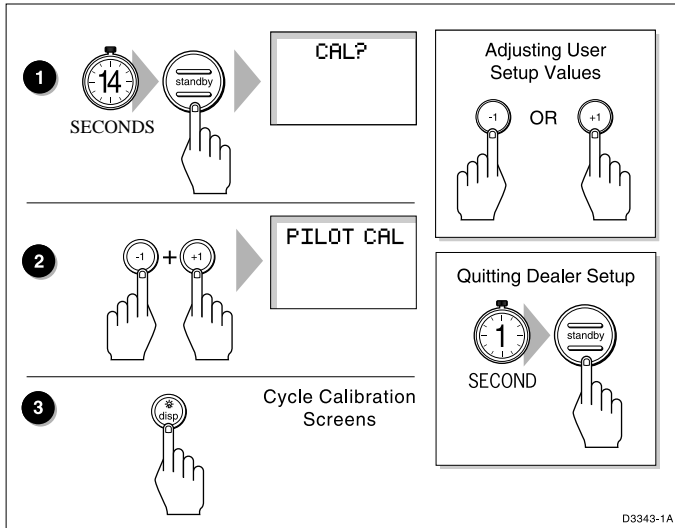

Recommended settings

The following pages list the default calibration settings for sailing/ power displacement and planing power vessels. Once you have set the Pilot Type, these will provide good performance for initial sea trials and can be fine tuned later to optimise performance.

After initial calibration has been carried out, further adjustment can be made at any time.

The features that can be adjusted are listed in the table at the end of this chapter, where you can record your settings for future reference. Information on the functions of the different settings is given in the remainder of this section.

The following points should be noted:

- Make sure that the autopilot is in Standby mode before you access Dealer Setup
- Setup options are always saved on exit

Pilot type

This should be set when the system is first switched on. The default settings for other Dealer Setup options depend on the pilot type you select here.

Setting	Description
DISPL MNT	Displacement
SEMI DIS	Semi-displacement
PLANING	Planing
STERN DRV	Sterndrive
Default:	Displacement

Calibration lock

Calibration lock controls whether User Setup and Intermediate Setup are available, and is intended for charter boat users.

Setting	Description
ON	Setup ON
OFF	Setup OFF
Default:	OFF

Rudder gain

This must be set while under way, as described in *Chapter 7, Post Installation Procedures*.

Range:	1 to 9
Default:	5 (Displacement) 5 (Semi-displacement) 4 (Planing) 3 (Sterndrive)

Rate level

Rate Level applies rudder to reduce rate or changes of course. Rate level will, if the rate at which the vessel is turning is too fast, counter this turn with opposite rudder.

The settings available are as follows:

Range:	1 to 9	
Defaults:	7	Displacement
	7	Semi-displacement
	7	Planing
	5	Stern drive

Rudder offset

You only need to set this option if your system includes a rudder reference unit.

- Manually place the helm in a central position. The reported rudder angle is indicated on the rudder bar graphic at the bottom of the screen.
- Adjust the offset value, using the **+1** and **-1** keys, until the rudder position is shown as central on the rudder bar. The offset must be within the range -7° to $+7^{\circ}$.

Range:	-7° to $+7^{\circ}$
Default:	0

Rudder limit

Rudder Limit restricts autopilot rudder movement to just less than the steering system's mechanical stops. This avoids putting the steering system under unnecessary load.

The range available is as follows:

Range:	15° to 40°
Defaults:	30° Displacement, semi-displacement, planing 20° Stern drive

Turn limit

This limits the rate of turn of your vessel when making a course change under pilot control. The value must be within the range 5 to 20° . For sailboat applications it should be set to 20° .

Range: 5° to 20° per second

Default: 20° (Displacement)
15° (Semi-displacement)
08° (Sterndrive)

Cruise speed

Cruise speed should be set to the boats normal cruising speed if boat speed is not available via SeaTalk or NMEA – SeaTalk boat speed is used in preference to SOG.

Range: 4 to 60 knots

Defaults: 6 Displacement
8 Semi-displacement
15 Planing
15 Sterndrive

Off course alarm

This feature controls the alarm that warns you if the pilot is unable to maintain its set course. The alarm operates if the autopilot strays off course by more than the alarm angle limit for more than 20 seconds.

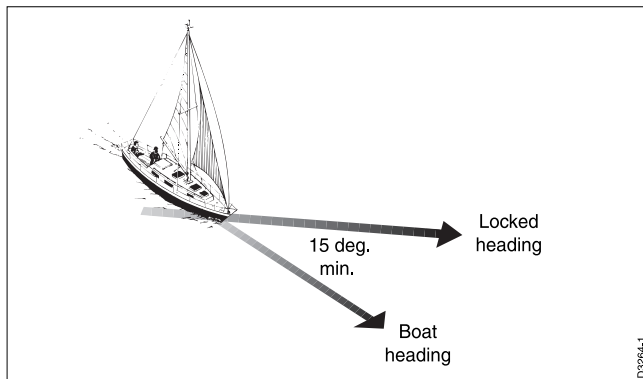

The value must be within the range 15 to 40°, and can be adjusted in 1° steps.

Range: 15 to 40°

Default: 20°

AutoTrim

The AutoTrim level setting determines the rate at which the autopilot applies “standing helm” to correct for trim changes caused by varying wind loads on the sails or superstructure. The settings are:

Setting	Effect	Recommended for:
Off	No trim correction	
1	Slow trim correction	Heavy displacement vessels, with full keel or transom rudder.
2	Medium trim correction	Heavy displacement vessels.
3	Fast trim correction	Moderate to light displacement vessels.
4	Super fast correction	Planing power vessels
Defaults:	Displacement	2
	Semi displacement	3
	Planing	3
	Sterndrive	3

The default setting (Level 3) should provide optimum performance with the ST6000 Plus autopilot. However, depending on the vessel’s dynamic stability, an incorrect rate of trim application may result in poor course keeping due to autopilot instability.

After gaining experience with the ST6000 Plus, you may wish to change the setting. The effect of the setting must be evaluated while under sail.

- Decrease the AutoTrim level if the autopilot gives unstable course keeping or excessive drive activity with a change in the heel angle.
- Increase the AutoTrim level if the autopilot reacts slowly to a heading change due to a change in the heel angle.
- For systems without a rudder reference unit, these settings have no effect and trim is set to level 3.

Power steer

Power steer selects the Joystick mode of operation: Proportional or ‘Bang-Bang’.

Proportional applies rudder in proportion to Joystick movement - the further the Joystick is held over the greater the applied rudder.

Bang-Bang applies continous rudder drive in the direction of lever movement. To improve control the speed of rudder movement changes with the angle of the lever. For maximum speed push the lever hardover. If the lever is returned to the center position the rudder will remain in its current position.

The settings available are as follows:

Range:	0 = Off 1 = Proportional 2 = Bang-bang
--------	--

Default:	Off
----------	-----

Drive type

The drive type controls the way which the autopilot drives the steering system. The default setting should be retained for mechanically driven vessels.

Range:	1 = Mechanically driven vessels without a rudder reference unit 2 = Hydraulic, no rudder reference unit 3 = Linear, rotary and sterndrive with a rudder reference unit 4 = Hydraulic with rudder reference unit
--------	--

Default:	Displacement 3, semi displacement 4, planing and 4 sterndrive 3
----------	---

Rudder damping

Set this option only if your system includes a rudder reference unit, and the drive “hunts” when trying to position the rudder.

Test for this when your vessel is moored dockside, by pressing **auto** and then **+10**. If the helm overshoots and has to drive back, or starts to hunt back and forth, increase the damping level.

Alternatively, you can set a value between 1 to 9. Adjust the damping one level at a time, and always use the lowest acceptable value.

Range:	1 to 9
--------	--------

Default:	2
----------	---

Variation

If required, set this value to the level of magnetic variation present at your vessel's current position. +ve variation = East, -ve variation = West. The variation setting is sent to other instruments on the SeaTalk system, and can be updated by other SeaTalk instruments.

Range:	-30° to +30°
--------	--------------

Default:	Off
----------	-----

AutoAdapt

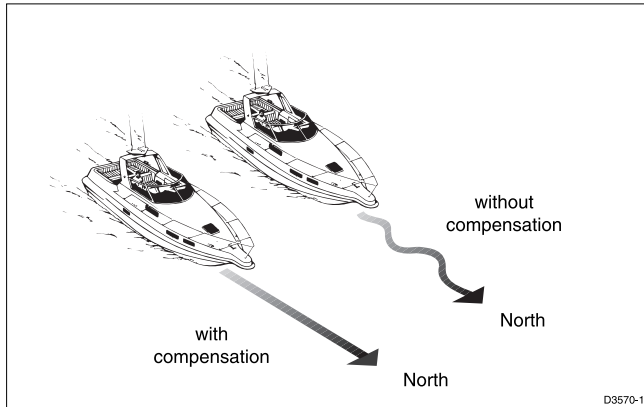

The patented AutoAdapt feature allows the ST6000 Plus to compensate for heading errors at higher latitudes, which are caused by the increasing dip of the earth's magnetic field. The increased dip has the effect of amplifying rudder response on northerly headings in the northern hemisphere, and on southerly headings in the southern hemisphere.

Set AutoAdapt to n in the northern hemisphere, or s in the southern hemisphere. You then need to enter your current latitude in the next setup screen, so that the ST6000 Plus can provide accurate course keeping by automatically adjusting the rudder gain depending on the heading.

Range:	Off = Off nth = North Sth = South
--------	---

Default:	Off
----------	-----

Latitude

This screen is only used if AutoAdapt is set to North or South.

Use the **+1**, **-1**, **+10**, and **-10** keys to set the value to your vessel's current latitude, to the nearest degree.

Range:	0 to 80°
--------	----------

Default:	Off
----------	-----

Note: *If valid latitude data is available via SeaTalk or NMEA, it will be used instead of this calibration value.*

Wind Trim

This varies the response of the autopilot when in wind mode.

The settings available are as follows:

Range:	1 Normal setting 2 Faster response for wind shifts
--------	---

Default:	1
----------	---

Tack angle

This adjusts the heading change controlled by the Auto Tack feature (+1 and +10 or -1 and -10)

The settings available are as follows:

Range:	40 to 125 degrees
--------	-------------------

Default:	100 degrees
----------	-------------

AutoRelease

AutoRelease provides emergency manual override, should it be necessary, to avoid an obstacle at the last moment. This option only applies to cable operated sterndrive actuators – for all other systems this option should be set to off.

Range:	Off On
Defaults:	0 for Displacement, Semi-displacement & Planing 1 for Stern drives

Response

This is the power-on response setting. The response level can be changed during normal operation (see section 3.3) or via the Response Data Page, if this is set for display (see section 2.6).

Range:	Level 1 (Auto Seastate) Level 2 (Auto sea state inhibit) Level 3 (Auto sea state inhibit counter rudder)
Default:	Level 1

Recording calibration settings

Having fine-tuned the calibration settings during initial sea trials, record them for future reference, in the table on the following page.

Feature	Setting
Pilot Type	
Calibration Lock	
Rudder gain	
Response	
Turn rate Limit	
Rudder Offset	
Off Course Alarm	
AutoTrim	
Drive Type	
Variation	
AutoAdapt	
Latitude	
Rudder Damping	
AutoRelease	
Cruise Speed	
Power Speed	
Rudder Limit	
Rate Level	

Chapter 6: Installation

6.1 Planning the Installation

This chapter explains how to install and connect the ST6000 Plus autopilot control unit. Before starting the installation, decide how you will site the unit and run the cables.

EMC installation guidelines

All Raytheon equipment and accessories are designed to the best industry standards for use in the leisure marine environment.

Their design and manufacture conforms to the appropriate Electromagnetic Compatibility (EMC) standards, but correct installation is required to ensure that performance is not compromised. Although every effort has been taken to ensure that they will perform under all conditions, it is important to understand what factors could affect the operation of the product.

To minimise the risk of operating problems, all Raytheon equipment and cables connected to it should be;

- At least 1m (3 feet) from any equipment transmitting or cables carrying radio signals e.g. VHF radios, cables and antennas. In the case of SSB radios, the distance should be increased to 2 m (7 ft).
- More than 2 m (7 ft) from the path of a radar beam. A radar beam can normally be assumed to spread 20 degrees above and below the radiating element.
- The equipment should be supplied from a different battery than the one used for engine start. Voltage drops below 10 V in the power supply to our products can cause the equipment to reset. This will not damage the equipment, but will cause the loss of some information and can change the operating mode.
- Raytheon specified cables should be used at all times. Cutting and rejoining these cables can compromise EMC performance and so must be avoided unless doing so is detailed in the installation manual.
- If a suppression ferrite is attached to a cable, this ferrite should not be removed. If the ferrite has to be removed during installation it must be reassembled in the same position.

The following illustration shows the typical range of suppression ferrites fitted to Raytheon equipment. Always use the ferrites specified by Raytheon.

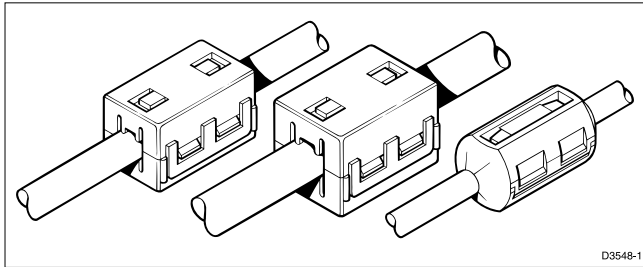

D3548-1

Connections to other equipment

If your Raytheon equipment is going to be connected to other equipment using a cable not supplied by Raytheon, a suppression ferrite **MUST** always be fitted to the cable close to the Raytheon unit.

Cabling

- Avoid running cables through bilges where possible
- Secure coiled lengths at regular intervals
- Avoid running cables close to fluorescent lights, engines, radio transmitting equipment etc

6.2 Control head

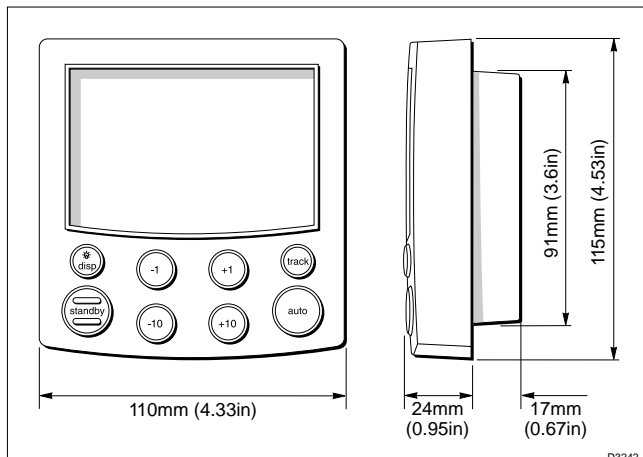

D3242-1

Siting

The control head is completely waterproof and should be sited where it is:

- Within easy reach of the steering position
- Protected from physical damage
- At least 230 mm (9 in) from any compass
- At least 500 mm (20 in) from any radio/radar receiving/transmitting equipment

Note: *The back cover is designed to breath through the cable boss to prevent moisture accumulation. This must be protected from the weather by following the mounting procedure.*

Mounting procedure

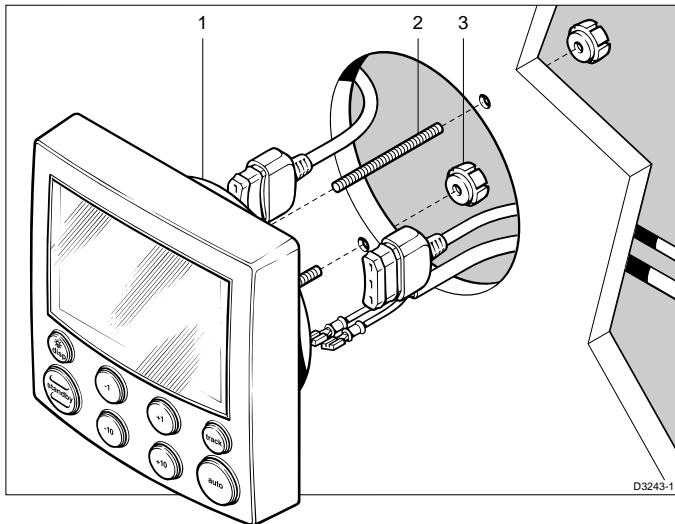

1 Cable boss 2 Fixing studs 3 Thumb nuts

Note: *Always leave a 6 mm (1/4 in) gap between adjacent display heads to allow the protective sun covers to be fitted.*

1. Use the template provided (near the end of this handbook) to mark the hole centres for the fixing stud and the cable boss.
2. Drill 4 mm (5/32 in) diameter holes for the fixing studs.
3. **Taking great care not to cut the hole for the cable boss too big,** use a 90 mm (3 1/2 in) diameter cutter to drill the hole for the cable boss (1).

4. Screw the fixing studs (2) into the display head.
5. Pass the cables (SeaTalk, NMEA) through the bulkhead.
6. Fit the cables to the appropriate terminals (see relevant subsection for connection details of each item)
7. Fit the display head to the bulkhead.
8. Assemble the thumb nuts (3) onto the fixing studs (2).
9. Tighten the thumb nuts by hand until the display head is secure.
Under no circumstances must wrenches be used to tighten the thumb nuts.

Connections to the SeaTalk bus

SeaTalk cables

The ST6000 Plus is supplied with a 9 m SeaTalk cable as standard.

The following table lists other cables available from your dealer:

Part No:	Type	Length
D187	Flat to a male round connector	0.15 m (6 in) long
D188	Flat to a female round connector	0.3 m (12 in) long
D284	Flat moulded plugs at both ends	1 m (3 ft 3 in) long
D285	Flat moulded plugs at both ends	3 m (9 ft 9 in) long
D286	Flat moulded plugs at both ends	6 m (19 ft 6 in) long
D287	Flat moulded plugs at both ends	9 m (29 ft 3 in) long

Cable types

The following illustration shows the different types of SeaTalk cables available.

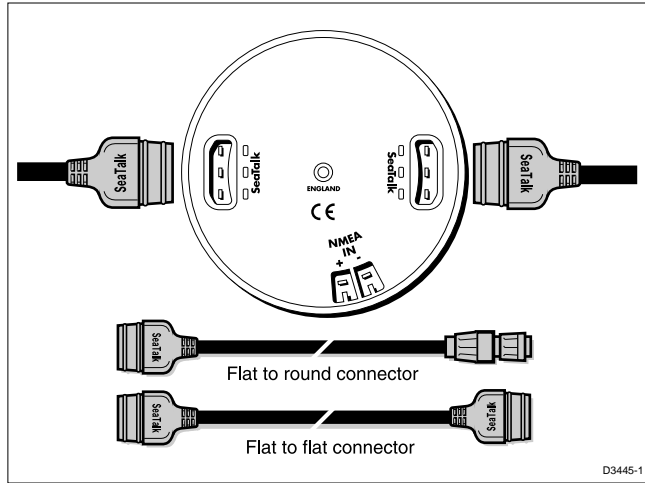

Typical SeaTalk cabling

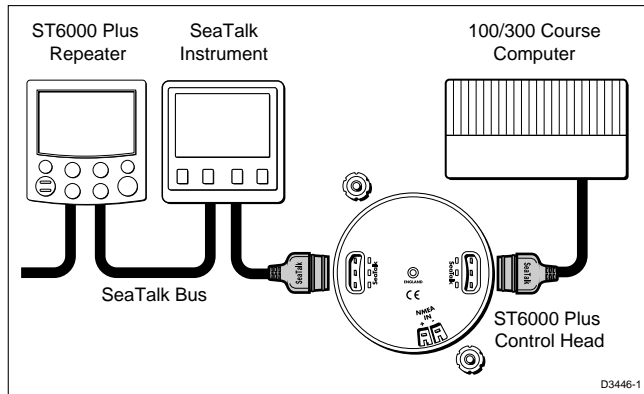

6.3 NMEA interface

ST6000 Plus accepts NMEA navigation data for display and use in Track and Vane modes. The required NMEA data formats are shown in the table at the end of this section.

Cabling

The NMEA port should be connected to a Navigator or Wind instrument.

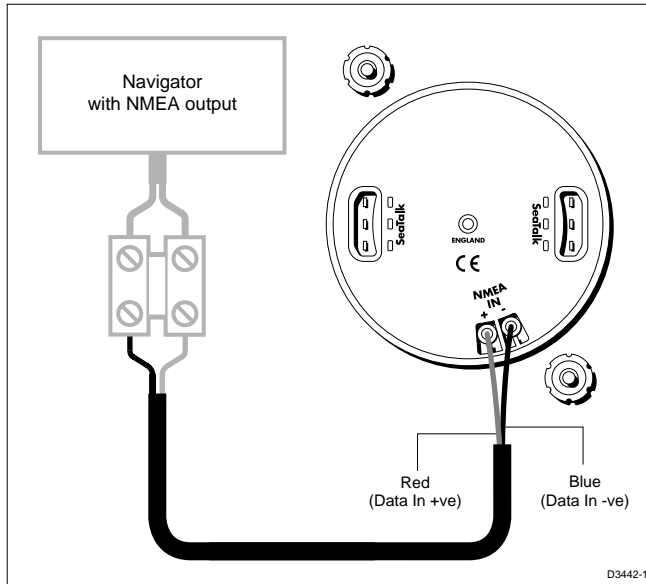

NMEA cable connectors

- NMEA connections are made using spade connectors.
- When fitting the spade connectors, make sure the connector fits securely over the blade and not between the connector and its plastic insulating boot – incorrect fitting will give intermittent contact which will lead to faulty autopilot operation.

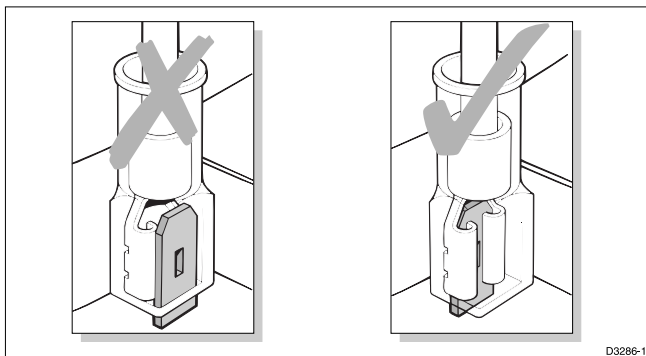

NMEA data transmission

If you wish to transmit NMEA information to other equipment a SeaTalk Interface should be installed.

The following NMEA 0183 wind and navigation data can be decoded by the ST6000 Plus.

Data	NMEA 0183
Latitude and Longitude	GLL, RMC, RMA, GLP, GOP, GXP, GGA, GDP
Course Over Ground	VTG, RMC, RMA
Speed Over Ground	VTG, RMC
Cross Track Error	APB, APA, RMB, XTE
Bearing to Waypoint	APA, APB, BWR, BWC, RMB
Distance to Waypoint	BWR, BWC, RMB
Waypoint Number	APB, APA, BWR, BWC, RMB
Apparent Wind Speed	VWR
Apparent Wind Angle	VWR, MWV
Speed Through Water	VHW
Depth	DBT
Water Temperature	MTW

Transmission of NMEA data on SeaTalk

If any of the above NMEA data is received and the equivalent data is not present on SeaTalk, the autopilot will transmit the data onto SeaTalk to make it available to other SeaTalk compatible instruments.

Depth is transmitted in the units defined by the first page in the data page rollover. Water temperature is always transmitted in °C.

6.4 Functional test (repeater unit)

If you have installed your ST6000 Plus as a repeater unit on an autopilot system, you should perform the functional test described in this section. However, if you have installed the ST6000 Plus as the only control unit for a Type 100/300 course computer, you should skip to *Chapter 7, Post Installation Procedures*, and follow the instructions given there.

Switch on

Having installed your ST6000 Plus, switch on the main power breaker. If the control head is active and the system operating, the following will occur:

- The control head beeps and displays the pilot type, ST6000.
- After the pilot type has been displayed for 2 seconds, the Standby mode screen should be displayed.

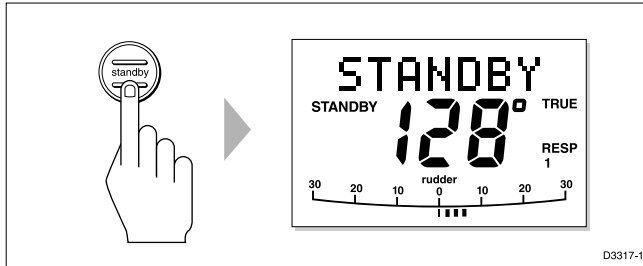

This shows that the control head is active. If the head does not beep, check the fuse/circuit breaker.

If the text ST FAIL or NO LINK is displayed, check the SeaTalk cables between the ST6000 Plus control head and the Course Computer.

Navigation interface (GPS, Decca, Loran)

If the ST6000 Plus is interfaced to a navigator, via its NMEA data port, the interface can be checked by displaying the default Data Pages. These are XTE, BTW, and DTW.

Press **disp** to display the first page, and check that the expected data is displayed. Press **disp** again to check each successive page.

If dashes are displayed instead of data values, the cause could be one or more of the following:

- A cabling error. Check for an open circuit, short circuit or reversed wires.
- The navigator is not configured to transmit the required data format.
- The signals being received by the navigator are too weak for reliable navigation. Refer to the navigator handbook for further action.

SeaTalk interface

If the ST6000 Plus has been linked to other SeaTalk instruments via SeaTalk, the link can be checked as follows:

1. Press **standby**.
2. Select display illumination level 3 on any other SeaTalk instrument or autopilot control unit.

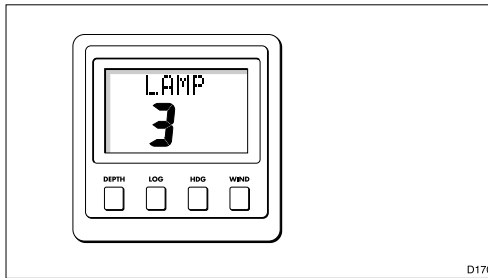

The ST6000 Plus should immediately respond by switching on its display illumination.

If the illumination does not switch on then a cabling fault exists in the SeaTalk cabling between the ST6000 Plus control head and the instruments/control unit.

Chapter 7: Post Installation Procedures

This chapter applies to systems where the ST6000 Plus has been installed as the only control unit for a Type 100/300 Course Computer.

Once you have installed the system, you need to confirm that it is wired correctly and is also set up to suit your type of boat.

This chapter provides instructions for the following procedures:

- **Functional test**, consisting of a few simple tests to confirm that the system is wired correctly
- **Initial sea trial**, to swing the compass and align the heading, check the autopilot's operation and check the rudder gain

Further customisation can be performed after the sea trial, as described in *Chapter 5*.

7.1 Functional test and initial calibration

Switch on

Having installed your ST6000 Plus system, switch on the main power breaker. If the control head is active and the system operating, the following will occur:

- The control head beeps and displays the pilot type as ST6000.
- After 2 seconds the Standby screen is displayed.

This shows that the control head is active.

- If the head does not beep, check the fuse/circuit breaker.
- If the SEATALK FAIL or NO LINK alarm is displayed, check the SeaTalk connections.

Initial calibration

Use the Dealer Setup function (see *Chapter 5*) as soon as you have completed this functional test.

Operating sense

The operating sense defines the direction the helm will be applied when a course change key is pressed or the vessel goes off course. Check the operating sense as follows:

1. Press **auto**.
2. Press the **+10** key. The helm should move to produce a turn to starboard.

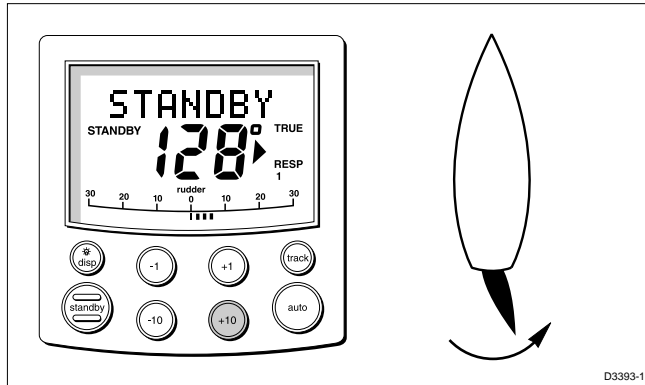

3. If the helm produces a turn to port, reverse the motor connections at the course computer.
4. If the helm overshoots and has to drive back or starts to hunt back and forth, you need to increase the Rudder Damping option in *Dealer Setup* (see *Chapter 5*).

Navigation interface (GPS, Decca, Loran)

If the ST6000 Plus is interfaced to a navigator, via its NMEA data port, the interface can be checked by displaying the default Data Pages. These are XTE, BTW, and DTW.

Press **disp** to display the first page, and check that the expected data is displayed. Press **disp** again to check each successive page.

If dashes are displayed instead of data values, the cause could be one or more of the following:

- A cabling error. Check for an open circuit, short circuit or reversed wires.
- The navigator is not configured to transmit the required data format.
- The signals being received by the navigator are too weak for reliable navigation. Refer to the navigator handbook for further action.

Wind transducer interface

If the ST6000 Plus is connected to a wind instrument via its NMEA data port or SeaTalk, then the link between the two instruments should be checked as follows:

- Press **standby** and **auto** together.

The ST6000 Plus should display the Vane mode screen, with the locked wind angle and locked heading as shown.

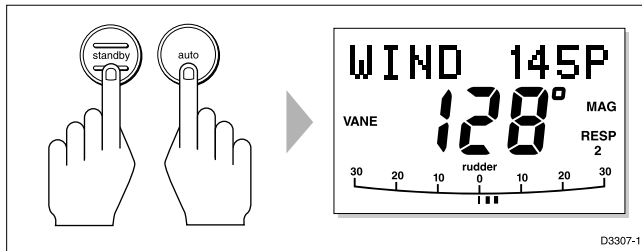

Alternatively, if the wind data is not received, the ST6000 Plus will display a NO DATA error message.

SeaTalk interface

If the ST6000 Plus has been linked to other SeaTalk instruments via SeaTalk, the link can be checked as follows:

1. Press **standby**.
2. Select display illumination level 3 on any other SeaTalk instrument or autopilot control unit.

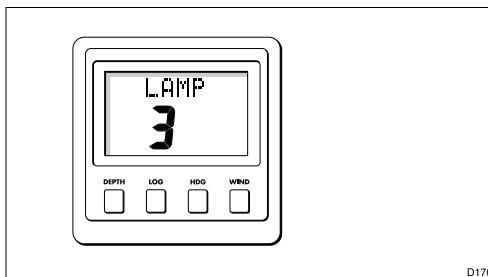

The ST6000 Plus should immediately respond by switching on its display illumination.

If the illumination does not switch on then a cabling fault exists in the SeaTalk cabling between the ST6000 Plus control head and the instruments/control unit.

7.2 Initial sea trial

EMC conformance

- Always check the installation before going to sea to make sure that it is not affected by radio transmissions, engine starting etc..
- In some installations, it may not be possible to prevent the equipment from being affected by external influences. In general this will not damage the equipment but can lead to it resetting, or momentarily may result in faulty operation.

Overview

Having checked that the system is functioning correctly, a short sea trial is now required to complete the setup. It involves the following procedures:

- Automatic compass deviation correction
- Heading alignment adjustment
- Autopilot operation check
- Rudder gain adjustment

Note: *The ST6000 Plus has a built-in calibration capability which enables it to be fine tuned to suit the individual vessel, its steering system and dynamic steering characteristics. As supplied from the factory the unit is calibrated to provide safe stable autopilot control for the majority of vessels.*

The initial sea trial should be performed in the following circumstances:

- After all the installation, functional test and initial calibration have been completed successfully
- Before any other changes have been made to the default calibration settings: check and, if necessary, reset the values to the recommended levels, as described in *Chapter 5*
- In conditions of light wind and calm water, so that autopilot performance can be assessed without the influence of strong winds or large waves
- In waters clear of any obstructions

Note: *At any time during the sea trial you can press **standby** to return to hand steering.*

Automatic compass deviation correction

The ST6000 Plus will correct the fluxgate compass for most deviating magnetic fields. Compass errors due to deviating magnetic fields can be up to 45°, depending on your vessel type. The correction procedure reduces these to a few degrees, so it is essential to perform the procedure as the first item in your initial sea trial.

CAUTION:

Failure to carry out the deviation correction may result in impaired autopilot performance on some compass headings.

To allow the system to determine the deviation and calculate any correction required, you must turn your vessel in slow circles. This procedure must be carried out in calm conditions and preferably in flat water.

To perform the deviation correction:

1. Make sure that the autopilot is in Standby mode .
2. Press and hold the **standby** key for 2 seconds to display the User Setup entry page.



If CAL LOCK is displayed, you need to turn off the lock feature contained in Dealer Setup (see *Chapter 5*).

3. Press the **disp** key to move on to the Swing Compass page.

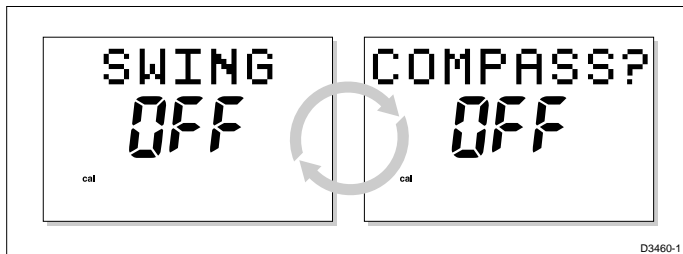

- Press the **+1** or **-1** key to change the setting from OFF to YES. The Turn Boat page is then displayed.

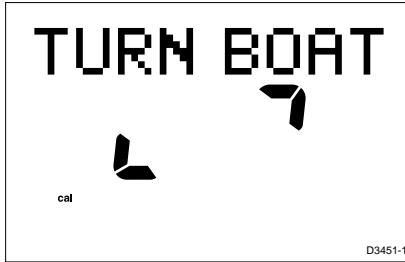

- Keeping the boat speed below 2 knots, turn the vessel in slow circles. It should take at least 3 minutes to complete 360°.

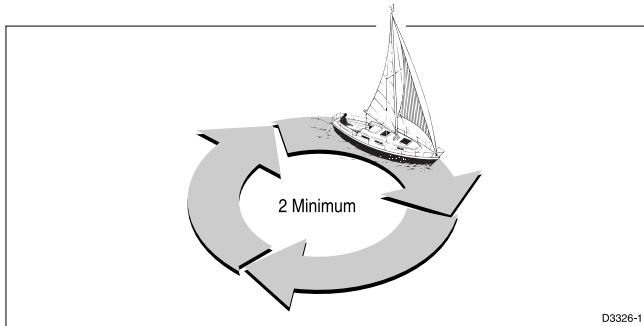

- Keep turning your boat until the unit beeps and the Deviation screen is displayed.



This shows the maximum deviation detected, and indicates that compass correction has been completed successfully.

Note: *If the deviation value exceeds 15°, you should consider moving the fluxgate compass to a better location.*

- Press the **disp** key to move on to the Heading Alignment page.



- Use the **+1** and **-1** keys, or the **+10** and **-10** keys, to increase or decrease the displayed heading, until it agrees with the ship's steering compass or a known transit bearing.

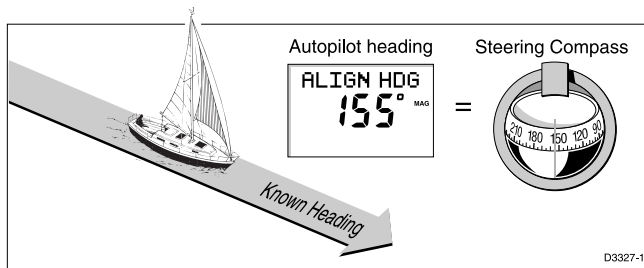

- Press and hold **standby** for 2 seconds to exit calibration and save the new settings.

Note: *Setup options are always saved on exit.*

Further heading alignment adjustment

You should always check the compass alignment after swinging the compass. However, once the initial deviation correction procedure has been performed, you can make adjustments to the alignment as often as you wish, without swinging the compass again.

Although the compass deviation correction procedure removes most of the alignment error, you will probably be left with small errors (of the order of a few degrees) that will vary depending on the heading.

Ideally, you should check the heading reading against a number of known headings, plot a deviation curve, and determine the heading alignment value that will give the lowest **average** alignment error. This value can then be entered on the Heading Alignment screen, as described above.

If the average heading error is more than 5°, you should perform the compass deviation correction procedure again.

Checking autopilot operation

Having calibrated the compass the following procedure is recommended to familiarise yourself with autopilot operation:

1. Steer onto a compass heading and hold the course steady.
2. Press **auto** to lock onto the current heading. A constant heading should be achieved in calm sea conditions.
3. Use the **-1**, **-10**, **+1** and **+10** keys to alter course to port or starboard in multiples of 1° and 10°
4. Press **standby** and disengage the autopilot to return to hand steering.

Checking the rudder gain

The factory set rudder gain level will provide stable control for initial sea trials. However, vessels can vary widely in their response to the helm, and further adjustment to the rudder gain may improve the autopilot's steering characteristics.

It is particularly important that the rudder gain is set correctly on high-speed craft. Incorrect adjustment will lead to poor steering performance and is a dangerous condition at high speed.

The following test will determine whether the rudder gain is set too high or too low.

1. In clear water and with the autopilot in Auto, alter course to starboard by 40° by pressing the **+ 10** key four times.
 - At cruising speeds, course changes of 40° should result in crisp turns followed by an overshoot of no more than 5°. If this occurs the rudder gain is adjusted correctly.
 - An excessively high rudder setting results in oversteer. This is recognised by a distinct overshoot of more than 5° (A). This condition can be corrected by reducing the rudder gain setting.
 - Similarly, an insufficient rudder control setting will result in understeer which gives sluggish steering performance (B). If the vessel takes a long time to make the turn and there is no overshoot then the rudder setting is too low.

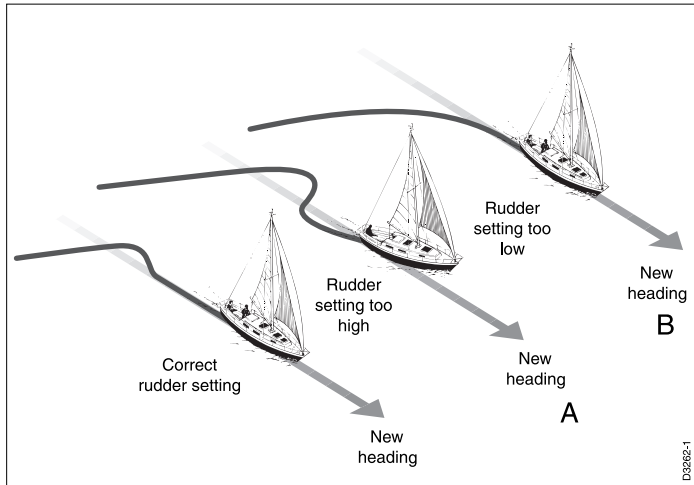

These actions are most easily recognised in calm sea conditions where wave action does not mask basic steering performance.

2. Refer to *Chapter 5, Customising the System*, for instructions on how to adjust the default rudder gain setting. Note that you can also make temporary adjustments to rudder gain during normal operation (see section 3.3).
3. Repeat the test until a crisp course change with no more 5° of overshoot is achieved.

The rudder control setting should be set to the lowest setting consistent with accurate course keeping. This will minimise helm movements and hence reduce power consumption and wear and tear.

Chapter 8: Maintenance

General

- In certain conditions, condensation may appear on the LCD window. This will not harm the unit, and can be cleared by switching on the illumination for a while.
- **Never** use chemical or abrasive materials to clean your autopilot. If the pilot is dirty, wipe it with a clean, damp cloth.
- Periodically check the cabling for chafing or damage to the outer casing – replace any damaged cables.

Servicing and safety

- Raytheon equipment should be serviced only by authorised Raytheon service engineers. They will ensure that service procedures and replacement parts used will not affect performance. There are no user serviceable parts in your autopilot control unit.
- Some products generate high voltages, and so never handle the cables/connectors when power is being supplied to the equipment.
- Always report any EMC related problem to your nearest Raytheon dealer. We will use any such information to improve our quality standards.

Advice

Should any difficulties arise with this product, please contact the Raytheon Product Support department in the UK, or your own national distributor who will be able to provide expert assistance.

The working parts of the drive system are sealed and lubricated for life during manufacture – servicing is not required.

Before you consider returning the autopilot, make sure that the power supply cable is sound and that all connections are tight and free from corrosion.

If the connections are secure, refer to the Fault Finding chapter of this handbook. If the fault cannot be traced or rectified, please contact your nearest Raytheon dealer or Service Centre.

Always quote the product serial number, which is printed on the rear cover of the autopilot, and the software version number, which is displayed when you enter Intermediate Setup (see *Chapter 5*).

Chapter 9: Fault Finding

All Raytheon products are subjected to a comprehensive test procedure prior to packing and shipping. In the unlikely event that a fault does occur with your autopilot, the following check list should help identify the problem and provide a cure.

The autopilot display is blank

- No power – check the fuse/circuit breaker.

The autopilot display shows CODE LOCK at power on

- The CodeLock code must be entered manually (see *Chapter 4*).

The displayed compass heading does not agree with the ships compass

- The compass has not been corrected for deviation – carry out the deviation and alignment procedures.

Vessel turns slowly and takes a long time to come on to course

- Rudder gain too low.

Vessel overshoots when turning on to a new course

- Rudder gain too high.

The autopilot appears to be unstable in Track mode, or track-holding is slow

- If tide speed exceeds 35% of boat speed, and boat speed is not available via SeaTalk, change the Cruise Speed setting in Dealer Setup to the boat's cruising speed.

The autopilot appears to be unstable on Northerly headings in the Northern hemisphere and Southerly headings in the Southern hemisphere

- Northerly/Southerly heading correction not set up.

Display shows CAL LOCK when entering calibration

- Calibration locked out – calibration protection feature is turned on in Dealer Setup.

The autopilot will not “talk” to other SeaTalk instruments

- Cabling problem – make sure all the cables are connected properly.

Position information not received

- Navigator not transmitting the correct position data.

The autopilot will not auto advance to the next waypoint

- No bearing to waypoint information received from the navigator.

A series of rotating dashes are displayed on screen

- Compass deviation correction or dockside rudder calibration is running.

The display shows a series of stationary dashes

- Data is not being received – check the cabling.

The display shows NO DATA

- The signals received from the navigator are too weak – refer to the navigator handbook for further action.

Index

A

- Adjusting the Locked Wind Angle 20
- Advance 18
- Advanced Operation 13
- Advice 69
- Alarms 24
- Apparent wind angle
 - Adjusting 20
 - Previous 21
- Auto mode 5
- AutoAdapt 45
- Automatic Acquisition 14
- Automatic Compass Deviation Correction 63
- Automatic Deadband 23
- Automatic track acquisition 14
- AutoRelease 47
- AutoSeastate 23
- AutoTack 7
 - To Port 8
 - To Starboard 7
 - Vane mode 22
- AutoTrim 43

B

- Bar graph 4
- Bar Selection 35
- Basic Operation 3

C

- Cabling 50, 69
- Calibration Lock 40
- Cancelling a Dodge Manoeuvre 18
- changed, or if the operating mode is changed.Wind 25
- Changing course 5
- Changing Course in Auto Mode 5
- Changing the Response Level 23
- Changing the Rudder Gain 24
- Checking Autopilot Operation 66
- Checking the Rudder Gain 66
- Code number 31
- Code Number Problems 32

- Compass alignment 64
- Compass Deviation Correction 35
- Compass deviation correction 35, 63
- Connections to the SeaTalk Bus 52
- Control Head 50
- Course changes 5
 - operating hints 9
- Course Changes Under Autopilot Control 9
- Cross Track Error 16
- Cross track error (XTE) 16
- Cruise Speed 42
- Cruise speed 47
- Customising the autopilot 33–48

D

- Data Not Received 26
- Data Pages 11, 36
 - Setting up 36
- Deadband 23
- Dealer Setup 38, 38–48
- Deviation 64
- Deviation Display 35
- Disengaging the autopilot 5
- Display layout 4
- djusting Autopilot Performance 23
- Dodges 18, 21
- Dodging Obstacles 6
- Dodging obstacles
 - Auto mode 6
 - Track mode 18
 - Vane mode 21
- Drive Stopped 25
- Drive Stopped alarm 25
- Drive type 44

E

- EMC
 - Conformance 62
 - Installation Guidelines 49
- Engaging the autopilot 5
- Entering Your Code 31

F

- Fault Finding 71
- Fault finding 71
- Functional test 55–57
 - course computer installations 59
- Functional Test (Repeater Unit) 55
- Further Heading Alignment Adjustment 65

G

- Graph use 35

H

- Hand steering 5
- Heading 6
- Heading alignment 35
- Heading alignment adjustment 65
- Heading mode 35

I

- Illumination 10
- Initial calibration 59
- Initiating a Dodge Manoeuvre 18
- Initiating Track Mode 13
- Installation 49
- Interfaces 56, 60
- Intermediate Setup 29

K

- Key functions 3
- Keypad Illumination 10

L

- Large Cross Track Error 25
- Large Cross Track Error alarm 16
- LAST HDG 6
- LAST WND 21
- Latitude 46
- Lighting 10
- Locked Wind Angle 20
- Low Battery 26
- Low Battery alarm 26

M

Maintenance 69
Major Course Changes 9
Man Overboard (MOB) 27
Manual Acquisition 15
Manual mode 10
Manual steering 5
Manual track acquisition 15
Master unit (CodeLock) 29
Minimum Deadband 23

N

Navigation data displays 11
Navigation Interface 56, 60
Navigation interface (GPS, Decca, Loran) 56, 60
NEXT WPT 26
NMEA Cable Connectors 54
NMEA Data Transmission 54
NMEA Interface 53
No Data alarm 26
No Link 25

O

Off Course 25
Off Course Alarm 8, 42
Off Course alarm 8
 Default angle 42
Operating Hints 9, 23
Operating modes 1
Operating sense 59
Operation in Vane Mode 19
Overview 1

P

Performance 23
Pilot type 39
Planning the Installation 49
Plot Frequency 19
Position Confirmation at the Start of a Passage 19
Post Installation Procedures 59
Power Steer 43
Previous Apparent Wind Angle 21
Previous heading 6
Previous Locked Heading 6

R

- Recommended Settings 39
- Recording Calibration Settings 47
- Response 41
- Response level 23
 - Default setting 41
- Returning to the Previous Locked Heading 6
- Rudder bar 35
- Rudder Calibration 36
- Rudder damping 46
- Rudder Gain 40
- Rudder gain 24, 40, 66
- Rudder Limit 41
- Rudder offset 41

S

- Safety 18
- Sea trial 62
- SeaTalk data displays 11
- SeaTalk Failure 25
- SeaTalk interface 57, 61
- Servicing 69
- Servicing and Safety 69
- Setting Waypoints 19
- Skipping a Waypoint 18
- Specification 2
- Standby mode 5
- Steering bar 35
- Swinging the compass 63
- Switch On 59

T

- Testing autopilot operation 66
- Testing the system 55–57, 59
- Tidal stream compensation 16
- Track acquisition 13
- Track Mode 13
- Track mode 13–14
- Typical SeaTalk Cabling 53

U

- User Setup 33

V

Vane Mode 20

Vane mode 19–20

Variation 45

Verifying Computed Positions 19

Version number 31

W

Watch alarm 27

Waypoint Advance 26

Waypoint arrival and advance 17

Wind Shift alarm 22

Wind transducer interface 61

Wind Trim 47

WindTrim 19, 19–20

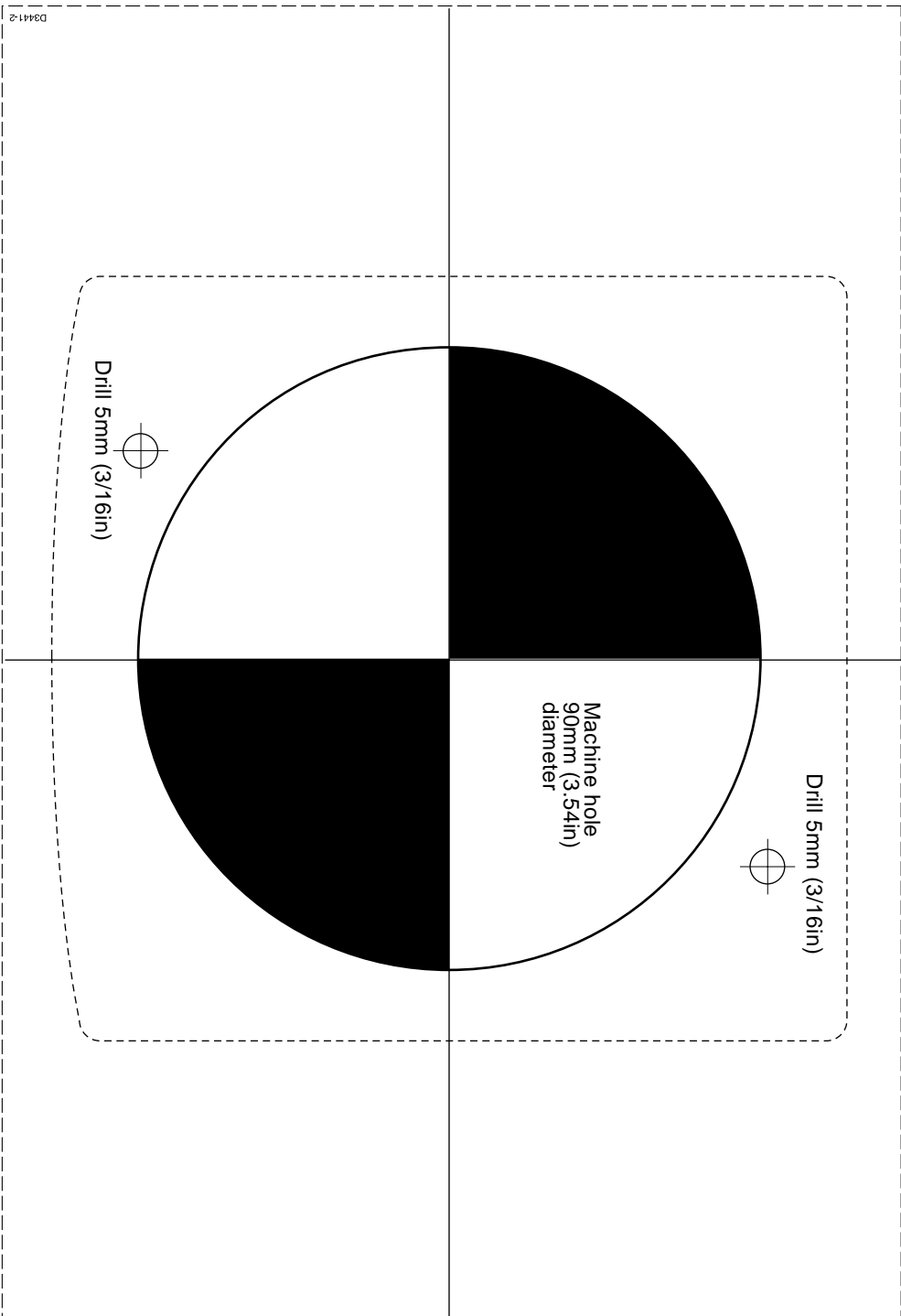

Machine hole
90mm (3.54in)
diameter

Drill 5mm (3/16in)

Drill 5mm (3/16in)

Limited Warranty Certificate

Raytheon Marine Company warrants each new Light Marine/Dealer Distributor Product to be of good materials and workmanship, and will repair or exchange any parts proven to be defective in material and workmanship under normal use for a period of 2 years/24 months from date of sale to end user, except as provided below.

Defects will be corrected by Raytheon Marine Company or an authorized Raytheon dealer. Raytheon Marine Company will, except as provided below, accept labor cost for a period of 2 years/24 months from the date of sale to end user. During this period, except for certain products, travel costs (auto mileage and tolls) up to 100 round trip highway miles and travel time of 2 hours, will be assumed by Raytheon Marine Company only on products where proof of installation or commission by authorized service agents, can be shown.

Warranty Limitations

Raytheon Marine Company Warranty policy does not apply to equipment which has been subjected to accident, abuse or misuse, shipping damage, alterations, corrosion, incorrect and/or non-authorized service, or equipment on which the serial number has been altered, mutilated or removed.

Except where Raytheon Marine Company or its authorized dealer has performed the installation, it assumes no responsibility for damage incurred during installation.

This Warranty does not cover routine system checkouts or alignment/calibration, unless required by replacement of part(s) in the area being aligned.

A suitable proof of purchase, showing date, place, and serial number must be made available to Raytheon Marine Company or authorized service agent at the time of request for Warranty service.

Consumable items, (such as: Chart paper, lamps, fuses, batteries, styli, stylus/drive belts, radar mixer crystals/diodes, snap-in impeller carriers, impellers, impeller bearings, and impeller shaft) are specifically excluded from this Warranty.

Magnetrons, Cathode Ray Tubes (CRT), hailer horns and transducers are warranted for 1 year/12 months from date of sale. These items must be returned to a Raytheon Marine Company facility.

All costs associated with transducer replacement, other than the cost of the transducer itself, are specifically excluded from this Warranty.

Overtime premium labor portion of services outside of normal working hours is not covered by this Warranty.

Travel cost allowance on certain products with a suggested retail price below \$2500.00 is not authorized. When/ or if repairs are necessary, these products must be forwarded to a Raytheon Marine Company facility or an authorized dealer at owner's expense will be returned via surface carrier at no cost to the owner.

Travel costs other than auto mileage, tolls and two (2) hours travel time, are specifically excluded on all products. Travel costs which are excluded from the coverage of this Warranty include but are not limited to: taxi, launch fees, aircraft rental, subsistence, customs, shipping and communication charges etc..

Travel costs, mileage and time, in excess to that allowed must have prior approval in writing.

TO THE EXTENT CONSISTENT WITH STATE AND FEDERAL LAW:

(1) THIS WARRANTY IS STRICTLY LIMITED TO THE TERMS INDICATED HEREIN, AND NO OTHER WARRANTIES OR REMEDIES SHALL BE BINDING ON RAYTHEON MARINE COMPANY INCLUDING WITHOUT LIMITATION ANY WARRANTIES OF MERCHANTABILITY OR FITNESS FOR A PARTICULAR PURPOSE.

(2) Raytheon Marine Company shall not be liable for any incidental, consequential or special (including punitive or multiple) damages.

All Raytheon Marine Company products sold or provided hereunder are merely aids to navigation. It is the responsibility of the user to exercise discretion and proper navigational skill independent of any Raytheon equipment.

United States of America

Raytheon Marine Company
Recreational Products
676 Island Pond Road
Manchester, NH 03109-5420
U.S.A.

Tel 603-647-7530
Fax 603-634-4756

UK, Europe, Middle East, Far East

Raytheon Marine Company
Recreational Products
Anchorage Park, Portsmouth
PO3 5TD, England

Tel (44) 1705 693611
Fax (44) 1705 694642
Customer support (44) 1705 661228

Raytheon

Factory Service Centers

United States of America

Raytheon Marine Company
address as above

UK, Europe, Middle East, Far East

Raytheon Marine Company
address as above



Purchased from _____

Purchase date _____

Dealer Address _____

Installed by _____

Installation date _____

Commissioned by _____

Commissioning date _____

Owner's name _____

Mailing address _____

This portion of card should be completed and retained by the owner.